

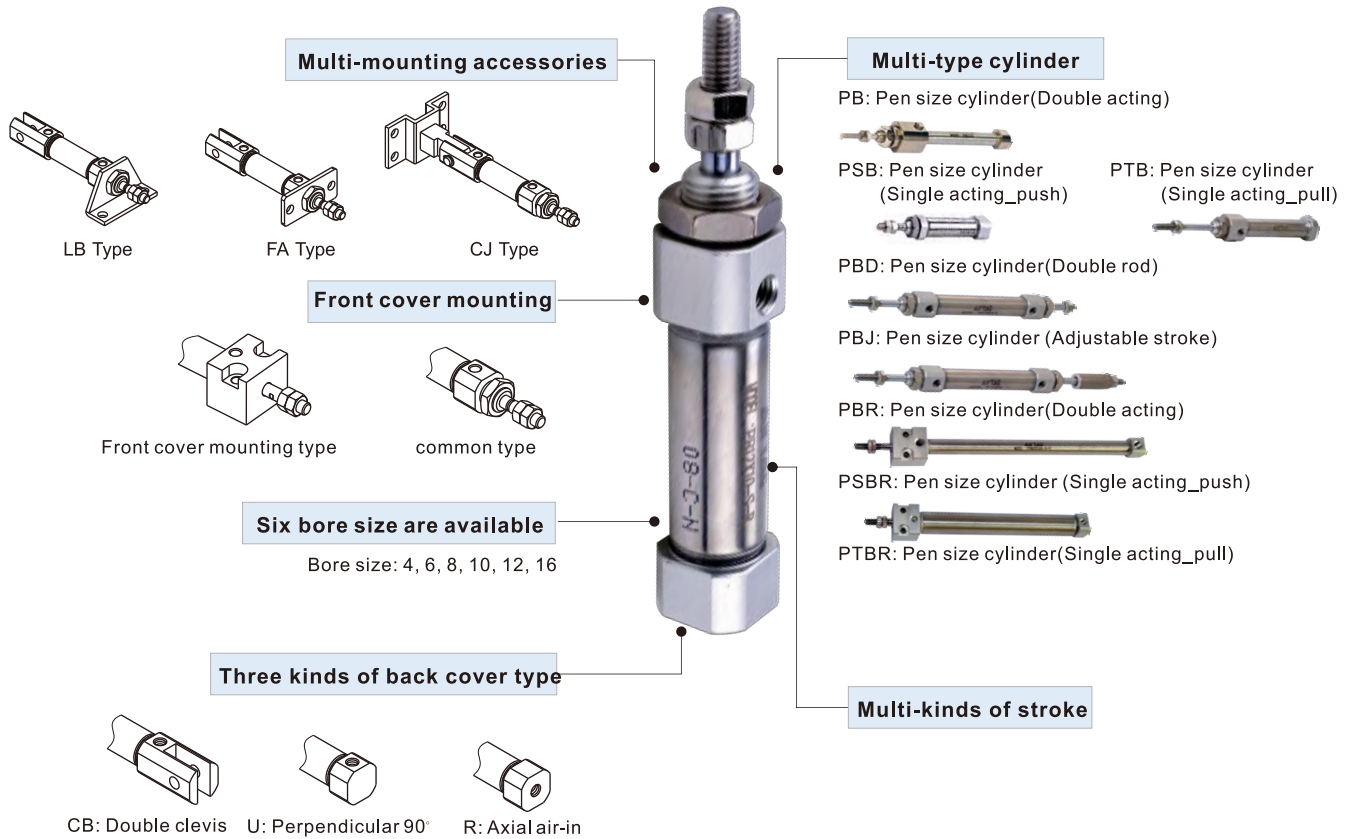

Pen size cylinder—PB Series

Compendium of PB Series



Criteria for selection: Cylinder thrust

Unit: Newton(N)

Bore size	Rod size	Acting type	Pressure area(mm ²)	Operating pressure (MPa)						
				0.1	0.2	0.3	0.4	0.5	0.6	0.7
4	2	Single acting_Push side	12.6	-	0.3	1.6	2.8	4.1	5.3	6.6
		Double acting Push side	12.6	1.3	2.5	3.8	5.0	6.3	7.6	8.8
		Double acting Pull side	9.4	0.9	1.9	2.8	3.8	4.7	5.6	6.6
6	3	Single acting Push side	28.3	-	2.2	5.0	7.8	10.6	13.5	16.3
		Single acting Pull side	21.2	-	0.7	2.9	5.0	7.1	9.2	11.3
		Double acting Push side	28.3	2.8	5.7	8.5	11.3	14.2	17.0	19.8
8	4	Double acting Pull side	21.2	2.1	4.2	6.4	8.5	10.6	12.7	14.8
		Single acting Push side	50.3	-	3.6	8.6	13.6	18.7	23.7	28.7
		Single acting Pull side	37.7	-	1.0	4.8	8.6	12.4	16.1	19.9
10	4	Double acting Push side	50.3	5.0	10.1	15.1	20.1	25.2	30.2	35.2
		Double acting Pull side	37.7	3.8	7.5	11.3	15.1	18.9	22.6	26.4
		Single acting Push side	78.5	-	6.2	14.1	21.9	29.8	37.6	45.5
12	5	Single acting Pull side	65.9	-	3.7	10.3	16.9	23.5	30.1	36.7
		Double acting Push side	78.5	7.9	15.7	23.6	31.4	39.3	47.1	55.0
		Double acting Pull side	65.9	6.6	13.2	19.8	26.4	33.0	39.5	46.2
16	5	Single acting Push side	113.0	-	9.0	20.3	31.6	42.9	54.2	65.5
		Single acting Pull side	93.4	-	5.1	14.4	23.8	33.1	42.4	51.8
		Double acting Push side	113.0	11.3	22.6	33.9	45.2	56.5	67.8	79.1
16	5	Double acting Pull side	93.4	9.3	18.7	28.0	37.4	46.7	56.0	65.4
		Single acting Push side	201.0	-	14.5	34.6	54.7	74.8	94.9	115.0
		Single acting Pull side	181.3	-	10.6	28.7	46.8	65.0	83.1	101.2
16	5	Double acting Push side	201.0	20.1	40.2	60.3	80.4	100.5	120.6	140.7
		Double acting Pull side	181.3	18.1	36.3	54.4	72.5	90.7	108.8	126.9

Installation and application



1. When load changes in the work, the cylinder with abundant output capacity shall be selected.
2. Relative cylinder with high temperature resistance or corrosion resistance shall be chosen under the condition of high temperature or corrosion.
3. Necessary protection measure shall be taken in the environment with higher humidity, much dust or water drops, oil dust and welding dregs.
4. Dirty substances in the pipe must be eliminated before cylinder is connected with pipeline to prevent the entrance of particles into the cylinder.
5. The medium used by cylinder shall be filtered to 40μm or below.
6. Anti-freezing measure shall be adopted under low temperature environment to prevent moisture freezing.
7. The load of the cylinder with the diameter of Φ4 needs to be coaxial with the cylinder to avoid side load, otherwise, piston rod will be bent and deformed and damage the thread at the end of the rod. Single-acting type can not be added in return.
8. If the cylinder is dismantled and stored for a long time, Please to conduct anti-rust treatment to the surface. Anti-dust caps shall be added in air inlet and outlet ports. The front and back cover can not be dismantled, which shall be especially noticed.



Pen size cylinder

PB Series



Specification

Bore size(mm)	4	6	10	12	16
Acting type	Double acting、Single acting_Push		Double acting、Single acting		
Fluid	Air(to be filtered by 40μm filter element)				
Operating pressure	Double acting	0.2~0.7MPa(28~100psi)(2.0~7.0bar)		0.15~0.7MPa(22~100psi)(1.5~7.0bar)	
	Single acting	0.3~0.7MPa(45~100psi)(3.0~7.0bar)		0.2~0.7MPa(28~100psi)(2.0~7.0bar)	
Proof pressure	1.2MPa(175psi)(12bar)				
Temperature °C	-20~70				
Speed range mm/s	50~500		50~800		
Stroke tolerance	-0.5 0		0~150 +1.0 0 >150 +1.5 0		
Cushion type	No cushion		Bumper		
Port size	Tube		M5×0.8		

Symbol

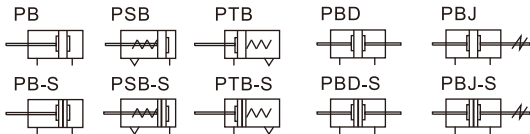

Product feature

- JIS standard is implemented.
- It belongs to mini cylinder that has compact structure, small volume and light weight.
- The guide precision of piston rod is high and no additional lubricant is needed.
- PB4 and PB6 can only be front mounted. PB10, PB12 and PB16 has the flexibility of both front and rear mount.
- Piston rod and cylinder body with the material of stainless steel make the cylinder adapt general working environment with corrosivity.
- There are cylinders and accessories with several specifications for installation for your choice.
- It has small cylinder diameter and quick reaction, suitable for the working environment with higher frequency.

Add) Refer to P576 for detail of sensor switch.

Stroke

Bore size (mm)	Standard stroke (mm)	Max.std stroke	Max. stroke
PB	4 5 10 15 20	20	20
	6 10 15 20 25 30 40 50 60	60	60
	10 10 15 20 25 30 40 50 60 75 80 100 125 150 160 175 200	200	200
	12 10 15 20 25 30 40 50 60 75 80 100 125 150 160 175 200	200	300
	16 10 15 20 25 30 40 50 60 75 80 100 125 150 160 175 200 250 300	300	300
PBD	6 5 10 15 20 25 30 40 50	50	-
	10 10 15 20 25 30 40 50 60 75 80 100	100	-
PBD PBJ	12 10 15 20 25 30 40 50 60 75 80 100 125 150 160 175 200	200	-
	16 10 15 20 25 30 40 50 60 75 80 100 125 150 160 175 200	200	-
	PSB 4 5 10 15 20	-	-
PSB PTB	6 5 10 15 20 25 30 40 50 60	-	-
	10 5 10 15 20 25 30 40 50 60	-	-
	12 5 10 15 20 25 30 40 50 60	-	-
	16 5 10 15 20 25 30 40 50 60	-	-

[Note] Consult us for non-standard stroke.

Ordering code

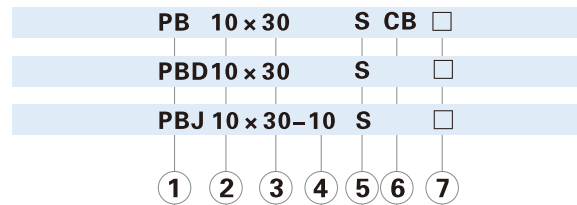

① Model	② Bore size	③ Stroke	④ Adjustable stroke	⑤ Magnet	⑥ Back cover			⑦ Mounting type[Note1]					
PB: Pen size cylinder (Double acting) PSB: Pen size cylinder (Single acting_push)	4	Refer to stroke table for details	No this code	Blank: Without magnet	Model	CB: Double clevis	Φ10~Φ16	PB PSB PTB	Blank: No accessories FA: FA type LB: LB type CJ: CJ type				
	6					U: Perpendicular 90°	Φ10~Φ16						
	10				R: Axial air-in	Φ6~Φ16							
	12				R: Axial air-in	Φ10~Φ16							
PTB: Pen size cylinder (Single acting_pull) PBD: Pen size cylinder (Double rod)	6			Refer to stroke table for details	No this code	Blank: Without magnet S: With magne	PTB	CB: Double clevis	Φ10~Φ16	PBD PBJ	Blank: No accessories FA: FA type LB: LB type		
	10							R: Axial air-in	Φ6~Φ16				
	12						No this code	-					
	16						No this code	-					
PBJ: Pen size cylinder (Adjustable stroke)	10					Refer to stroke table for details	10 20 30 40 50 75 100	Blank: Without magnet S: With magne	PBD PBJ	-		PBD PBJ	Blank: No accessories FA: FA type LB: LB type
	12									-			
	16									-			

[Note1] Please refer to page 308 for accessory parts.

Pen size cylinder

PB Series

Inner structure and material of major parts

Double acting without magnet

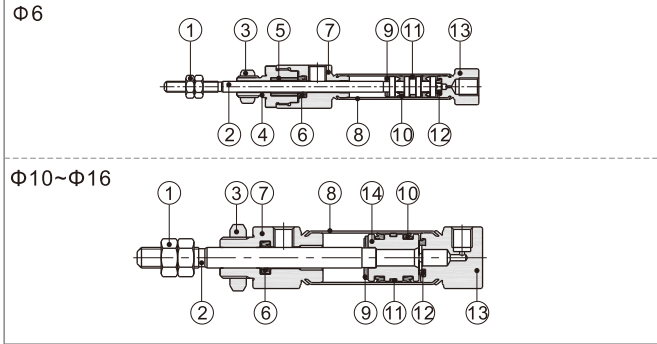

NO.	Item	Material
1	Rod nut	Carbon steel
2	Piston rod	SUS304
3	Front cover nut	Carbon steel
4	Packing retainer	Brass(Φ4)\Aluminum alloy(Others)
5	Bushing	Wear resistant material
6	Front cover O-ring	NBR
7	Front cover	Brass(Φ4)\Aluminum alloy(Others)
8	Barrel	Bronze(Φ4)\SUS304(Others)
9	Bumper	TPU
10	Piston seal	NBR
11	Wear ring	Wear resistant material
12	Bumper	TPU
13	Back cover	Brass(Φ4)\Aluminum alloy(Others)
14	Piston	Aluminum alloy(Φ16)\Stainless steel(Others)

Dimensions

PB

Φ4(Without magnet)(R Type)

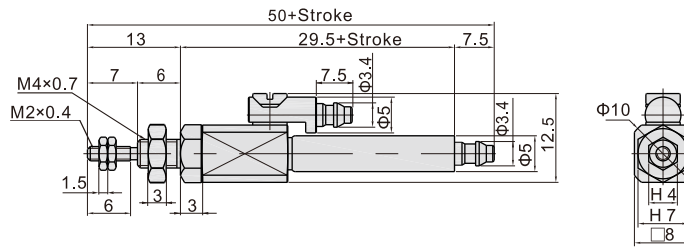

Φ6(R Type)

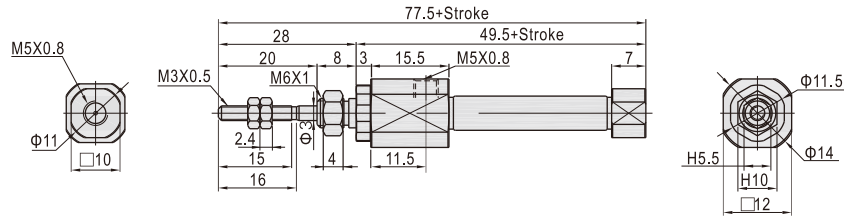

Note) Only axial air intake type of back cover is available for Φ4, Φ6mm bore size.

Φ10~Φ16

U Type(Perpendicular 90°)

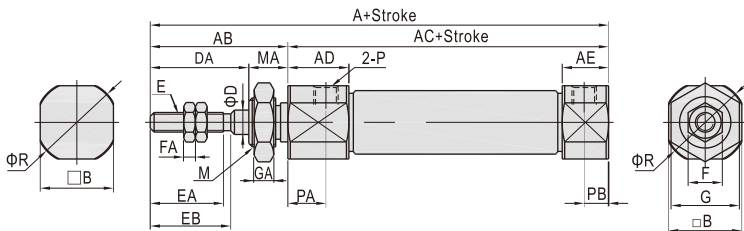

CB Type(Double clevis)

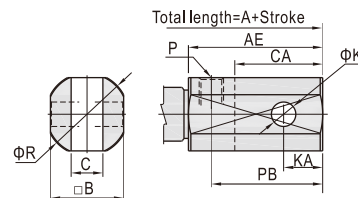

R Type(Axial air-in)

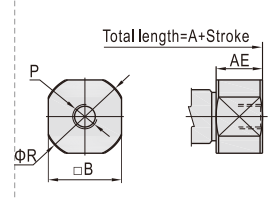

Bore size\Item	A			AB	AC	AD	AE		B	C	CA	D	DA	E	EA	EB	F	FA	G	GA	K	KA	M	MA	P	PA	PB		
	U	CB	R				U	R																			U	CB	R
10	74	87	74	28	46	11.5	9.5	22.5	12	3.3	13	4	20	M4×0.7	15	16.5	7	3	11	4	3.3	5	M8×1.0	8	M5×0.8	7.5	5	18	14
12	74	92	74	28	46	11.5	9.5	27.5	15	6.6	18	5	20	M5×0.8	15	16.5	8	4	14	4	5	8	M10×1.0	8	M5×0.8	7.5	5	23	17
16	76	94	76	28	48	12	9.5	27.5	18	6.6	18	5	20	M5×0.8	15	16.5	8	4	14	4	5	8	M10×1.0	8	M5×0.8	7.5	5	23	20

Remark: The dimensions of magnet type cylinder are the same as non-magnet type cylinder.

Pen size cylinder

PB Series

PSB $\Phi 4$ (Without magnet)(R Type)

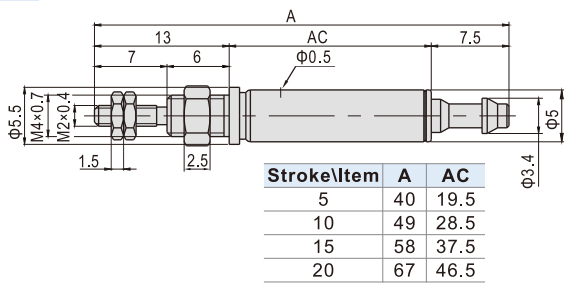

$\Phi 6$ (R Type)

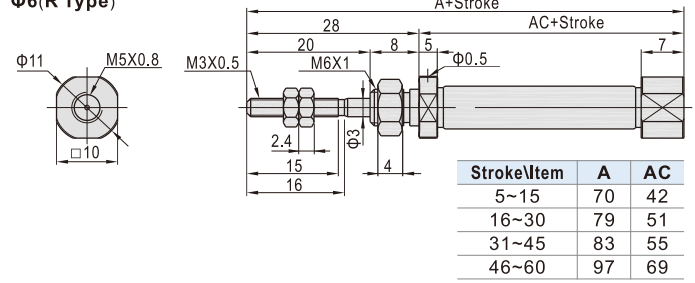

Note) Only axial air intake type of back cover is available for $\Phi 4$, $\Phi 6$ mm bore size.

$\Phi 10$ ~ $\Phi 16$ U Type(Perpendicular 90°)

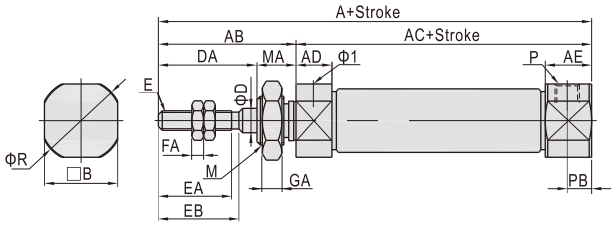

CB Type(Double clevis)

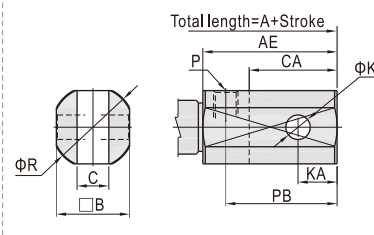

R Type(Axial air-in)

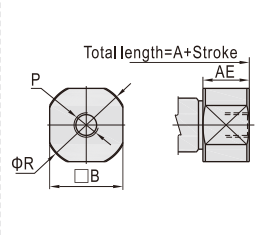

Bore size\Item Back cover	A												AB	AC				AD	AE		B	C
	U				CB				R					U/R	CB							
Stroke	5~15	16~30	31~45	46~60	5~15	16~30	31~45	46~60	5~15	16~30	31~45	46~60	5~15	16~30	31~45	46~60	-	-	-	-		
10	73.5	81	93	105	86.5	94	106	118	73.5	81	93	105	28	45.5	53	65	77	5	9.5	22.5	12	3.3
12	73.5	81	93	105	91.5	99	111	123	73.5	81	93	105	28	45.5	53	65	77	5	9.5	27.5	15	6.6
16	74.5	83	95	107	92.5	101	113	125	74.5	83	95	107	28	46.5	55	67	79	5	9.5	27.5	18	6.6

Bore size\Item Back cover	CA	D	DA	E	EA	EB	F	FA	G	GA	K	KA	M	MA	P	PB		R
																U	CB	
10	13	4	20	M4x0.7	15	16.5	7	3	11	4	3.3	5	M8x1.0	8	M5x0.8	5	18	14
12	18	5	20	M5x0.8	15	16.5	8	4	14	4	5	8	M10x1.0	8	M5x0.8	5	23	17
16	18	5	20	M5x0.8	15	16.5	8	4	14	4	5	8	M10x1.0	8	M5x0.8	5	23	20

Remark: The dimensions of magnet type cylinder are the same as non-magnet type cylinder.

PTB $\Phi 6$ (R Type)

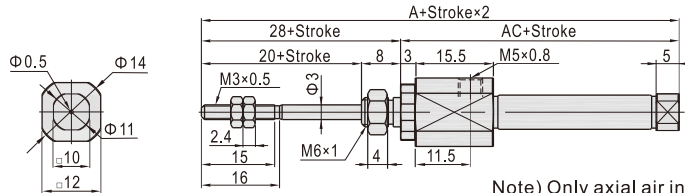

Stroke\Item	A	AC
5~15	82	54
16~30	91	63
31~45	95	67
46~60	109	81

Note) Only axial air intake type of back cover is available for $\Phi 6$ mm bore size.

$\Phi 10$ ~ $\Phi 16$ R Type(Axial air-in)

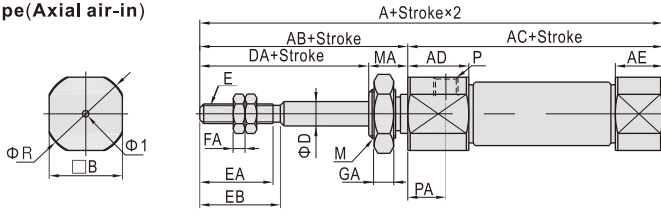

CB Type(Double clevis)

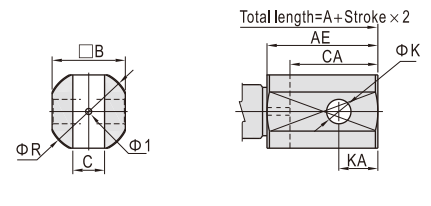

Bore size\Item Back cover	A								AB	AC				AD
	R				CB					5~15	16~30	31~45	46~60	
Stroke	5~15	16~30	31~45	46~60	5~15	16~30	31~45	46~60	5~15	16~30	31~45	46~60		
10	76.5	84	96	108	89.5	97	109	121	28	48.5	56	68	80	11.5
12	76.5	84	96	108	94.5	102	114	126	28	48.5	56	68	80	11.5
16	77.5	86	98	110	95.5	104	116	128	28	49.5	58	70	82	12

Bore size\Item Back cover	AE	R	CB	B	C	CA	D	DA	E	EA	EB	F	FA	G	GA	K	KA	M	MA	P	PA	R
	10	5	18	12	3.3	13	4	20	M4x0.7	15	16.5	7	3	11	4	3.3	5	M8x1.0	8	M5x0.8	7.5	14
12	5	23	15	6.6	18	5	20	M5x0.8	15	16.5	8	4	14	4	5	8	M10x1.0	8	M5x0.8	7.5	17	
16	5	23	18	6.6	18	5	20	M5x0.8	15	16.5	8	4	14	4	5	8	M10x1.0	8	M5x0.8	7.5	20	

Note) $\Phi 10$ ~ $\Phi 16$ bore sizes don't have perpendicular(90°) air-in.

Remark: The dimensions of magnet type cylinder are the same as non-magnet type cylinder.

Pen size cylinder

PB Series

PBD

Φ6

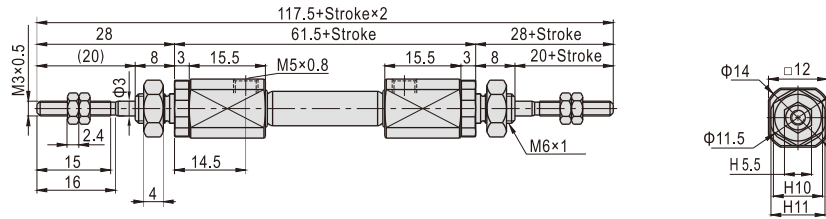

Φ10-Φ16

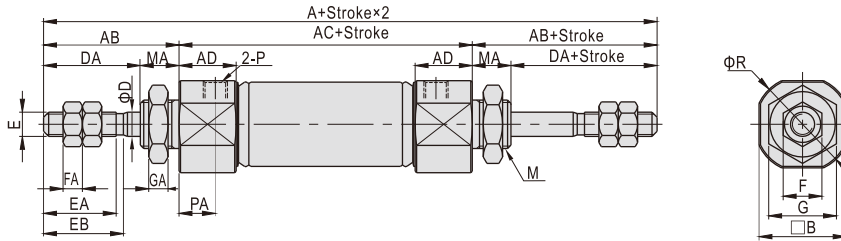

PBJ

Φ10-Φ16

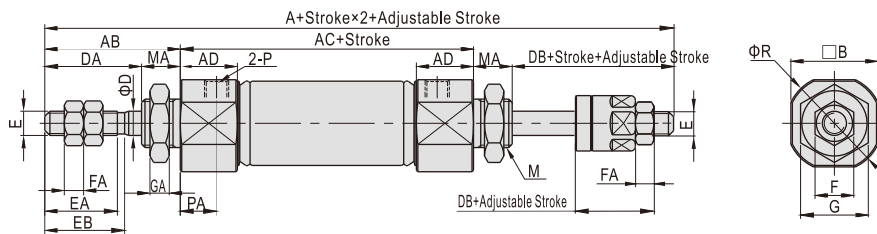

Bore size/Item Model	A		AB	AC	AD	B	D	DA	DB	E	EA	EB	F	FA	G	GA	M	MA	P	PA
	PBD	PBJ																		
10	104	99	28	48	11.5	12	4	20	15	M4×0.7	15	16.5	7	3	11	4	M8×1.0	8	M5×0.8	7.5
12	104	101	28	48	11.5	15	5	20	17	M5×0.8	15	16.5	8	4	14	4	M10×1.0	8	M5×0.8	7.5
16	107	104	28	51	12	18	5	20	17	M5×0.8	15	16.5	8	4	14	4	M10×1.0	8	M5×0.8	7.5

Remark: The dimensions of magnet type cylinder are the same as non-magnet type cylinder.