

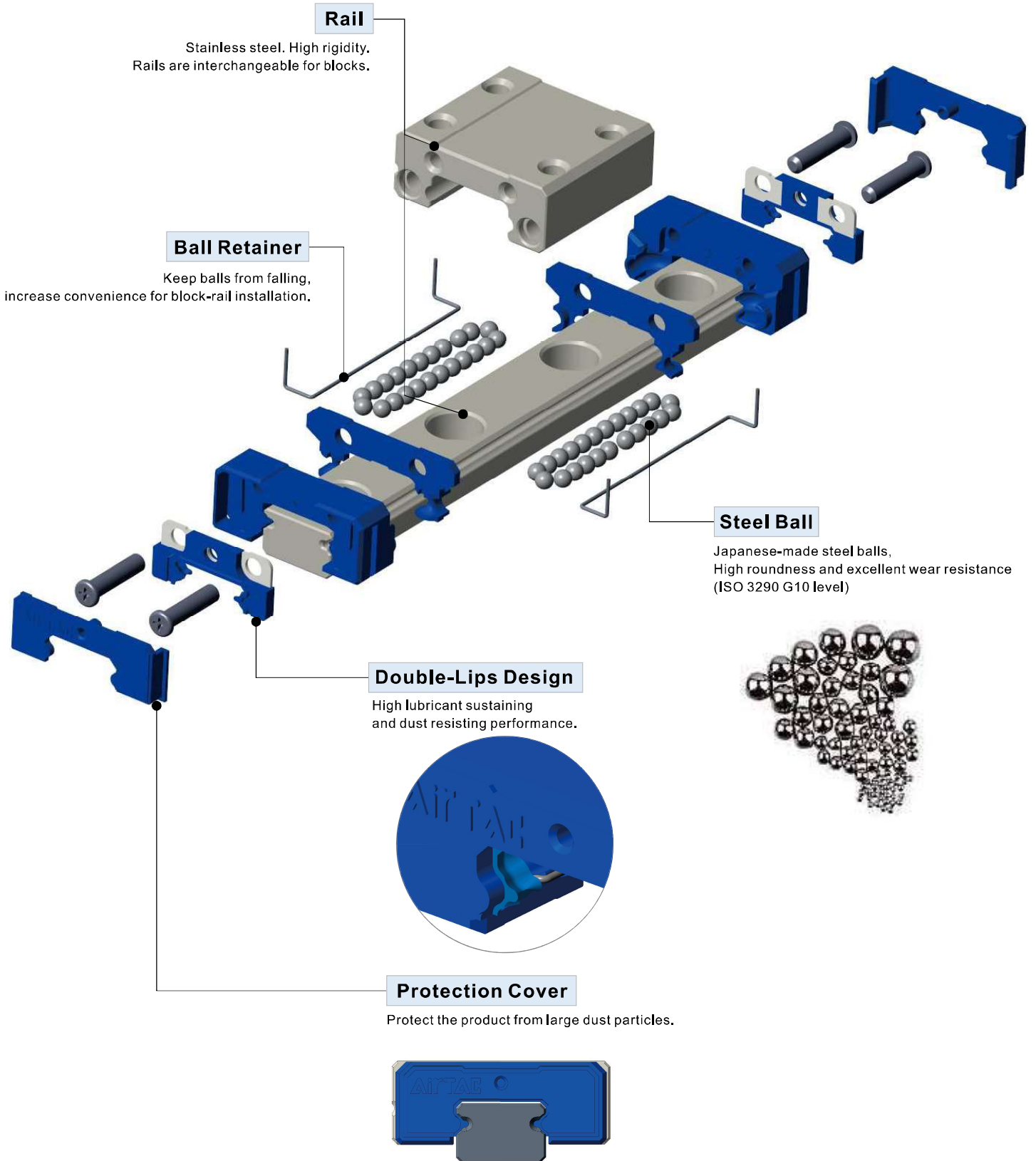

# LRM Series Miniature Linear Guide

## Product Introduction



## LRM Series



### Order Information(Combined)

LRM □ 7 N 1 X40 S5 A H T

① ② ③ ④ ⑤ ⑥ ⑦ ⑧ ⑨ ⑩

① Model Code	LRM : Miniature Linear Guide
② Rail&Block surface treatment	Blank: without additional coating. (natural color) ★BB: Block and rail coated with black chrome
③ Rail Width	5 : 5mm    7 : 7mm    9 : 9mm    12 : 12mm    15 : 15mm
④ Block type	N: Standard    L: Long
⑤ Number of Block	1: One    2: Two [Note: Amount of block on a single set of linear guide]
⑥ Rail Length	40: 40mm..... [Refer to rail spec. table for detail]
⑦ Position of first mounting hole	S□ : Distance from end of rail to the center of first mounting hole. (It is recommended to be greater than minimum edge) [Refer to rail spec table for details]
⑧ Preload	A: Standard clearance    B: Light Preload    C: Medium Preload
⑨ Accuracy	H : High    P : Precision
⑩ Rail type	Blank : Top-Mount    T : Bottom-Mount

Note: LRM5 without black chrome plating option

### Butt-jointed Order Information

LRM □ 7 N 1 X 705 T 705 A H T

① ② ③ ④ ⑤ ⑥ ⑦ ⑧ ⑨ ⑩ ⑪

① Model Code	LRM : Miniature Linear Guide
② Rail&Block surface treatment	Blank: without additional coating. (natural color) ★BB: Block and rail coated with black chrome
③ Rail Width	5 : 5mm    7 : 7mm    9 : 9mm    12 : 12mm    15 : 15mm
④ Block type	N: Standard    L: Long
⑤ Number of Block	1: One    2: Two [Note: Amount of block on a single set of linear guide]
⑥ Length of first Rail	705: 705mm .....[Defined by customer]
⑦ Butt-jointed mark	T: Rail Butt-jointed mark(Butt-jointed end margin:1/2P) [P is the standard hole distance]
⑧ Length of tail Rail	705: 705mm .....[Defined by customer]
⑨ Preload	A: Standard clearance    B: Light Preload    C: Medium Preload
⑩ Accuracy	H : High
⑪ Rail type	Blank : Top-Mount    T : Bottom-Mount

Butt-jointed end margin:1/2P ,  
Position of the first and last hole is defined by customer.

[Note 1] Allow only two rails for standard joint. Customization is needed for more than two rails.

[Note 2] Customization is needed if the first/last mounting hole position is out of range in 'Rail Specification Table'.

[Note 3] LRM5 without black chrome plating option

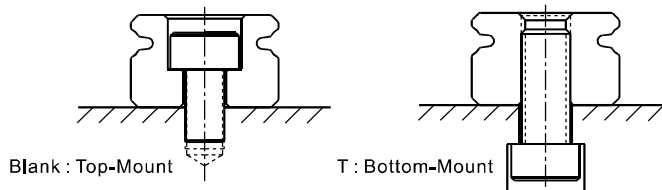

## LRM Series

### 1. Block Order Information

LRM □ 7 BK - N - H - D

Notes: 1. When selecting rails and bearings, the different pairing codes can change the units preload, details see "preload pairing chart".  
2. LRM5 block cannot be ordered individually.



① Model Code	LRM : Miniature Linear Guide
② Coating on block	Blank: Block without additional coating. (natural color) ★B: Block coated with black chrome
③ Rail Width	7 : 7mm 9 : 9mm 12 : 12mm 15 : 15mm
④ Block Code	BK: Block
⑤ Block Type	N: Standard L: Long
⑥ Accuracy	H : High
⑦ Group Code	B C D E [Note]

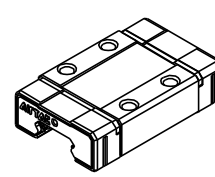

N: Standard

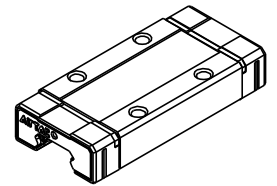

L: Long

### 2. Uncut Rail Order Information

LRM □ 7 RL X 985 - H - E - T

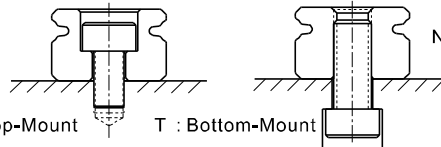

Blank : Top-Mount

T : Bottom-Mount

Note: 1. When selecting rails and bearings, the different pairing codes can change the units preload, details see "preload pairing chart".  
2. LRM5 rail cannot be ordered individually.

① Model Code	LRM: Miniature Linear Guide			
② Coating on rail	Blank: Rail without additional coating. (natural color) ★B: Rail coated with black chrome			
③ Rail Width	7:7mm	9:9mm	12:12mm	15:15mm
④ Rail Code	RL: Rail			
⑤ Rail Length	7:995mm	9:1005mm	12:1005mm	15:990mm
⑥ Accuracy	H : High			
⑦ Group Code	E [Note]			
⑧ Rail Type	Blank : Top-Mount		T : Bottom-Mount	

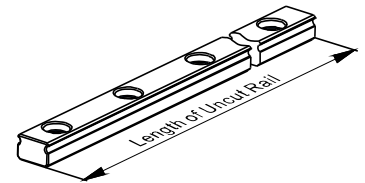

### 3. Rail Order Information

LRM □ 7 RLX40 - S5 - H - E - T



Note: 1. When selecting rails and bearings, the different pairing codes can change the units preload, details see "preload pairing chart".  
2. LRM5 rail cannot be ordered individually.

① Model Code	LRM: Miniature Linear Guide	
② Coating on rail	Blank: Rail without additional coating. (natural color) ★B: Rail coated with black chrome	
③ Rail Width	7 : 7mm	9 : 9mm 12 : 12mm 15 : 15mm
④ Rail Code	RL: Rail	
⑤ Rail Length	40: 40mm..... [Refer to rail spec. table for detail]	
⑥ Position of first mounting hole	S □ : Distance from end of rail to the center of first mounting hole. (It is recommended to be greater than minimum edge) [Refer to rail spec table for details]	
⑦ Accuracy	H : High	
⑧ Group Code	E [Note]	
⑨ Rail Type	Blank : Top-Mount T : Bottom-Mount	

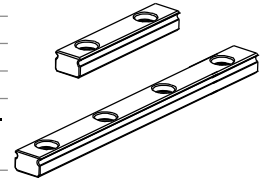

### 4. Accessory (Bolt hole plug) Order Code

L - BC - M3 - 10P



Note:  
1. Bolt hole plugs are packed in one bag per 10pcs. EX: When ordering 1pc of "L-BC-M3-10P", it comes with 10pcs plugs;  
2. "L-BC-M3-10P" is applied to LRM9/12/15 series;  
3. When mounting plugs for LRM9 series, short head bolts are required, bolt size is shown in the following figure.

① Accessories	L: Linear Guide Accessory
② Plug Code	BC: Bolt hole plug
③ Plug Specification	M3: Used for M3 bolt
④ Plug quantity	10P: 10pcs/bag

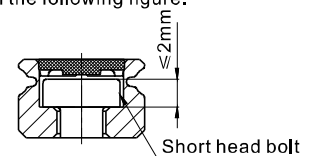

### 5. Rail/Block preload pairing chart

When customer orders rail/block, please choose the pairing code of rail/block in accordance with the needed preload of linear guide(combined). Details please refer to the "preload pairing chart".

LRM7、LRM9 Preload pairing chart		LRM12、LRM15 Preload pairing chart	
Preload grade	Rail pairing code	Preload grade	Rail pairing code
	E		E
Block pairing code	B	-	Medium preload
	C	Medium preload	Light preload
	D	Light preload	-
	E	Standard clearance	Standard clearance

## LRM Series

### Rail Specification

- Please refer to the chart for maximum individual rail length and Edge pitch information.
  - The edge pitch of first mounting hole (S) and last mounting hole (E) should not be greater than 1/2P. Overlong edge may induce unstable installation and affect the accuracy.
- n: Numbers of mounting holes

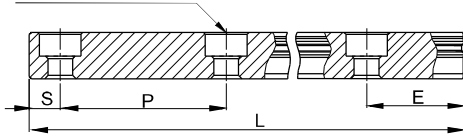

$$L = (n-1) \times P + S + E$$

L: Total length of rail(mm)

n: Numbers of mounting holes on rail

P: Distance between bolt holes(mm)

S: Edge of first mounting hole(mm)

E: Edge of last mounting hole(mm)

Model	LRM5	LRM7	LRM9	LRM12	LRM15
Pitch(P)	15	15	20	25	40
Standard edge pitch (S/E)	7.5	10	12.5	15	15
Min. Edge Pitch (S/E min)	3	3	4	4	4
Max. Edge Pitch (S/E max)	10	10	15	20	35
Maximum length(L max)(mm)	495	995	1005	1005	990

Note: ●Joint rail must be chosen if length of rail exceeds the maximum.

- When deciding edge pitch, it should be within the range of above table. There would be risk of broken hole if pitch is out of range.

### Specifications and Dimensions

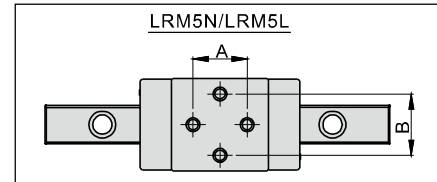
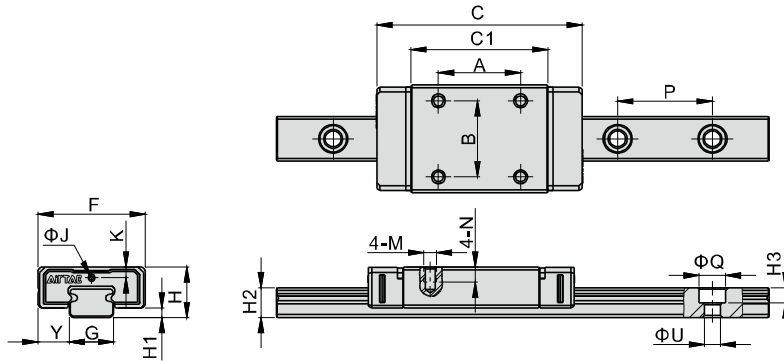

Rail type : Bottom-Mount

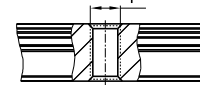

Model/Item	External Dimension ( mm )					Block Dimension ( mm )							Rail Dimension ( mm )						
	H	H1	F	Y	C	C1	A	B	M	N	K	ΦJ	G	H2	P	ΦQ	ΦU	H3	T
LRM5N	6	1.5	12	3.5	18.2	10	7	8	M2X0.4	1.5	1.3	0.7	5	3.5	15	3.5	2.2	1.1	M3X0.5
LRM5L	6	1.5	12	3.5	21.2	13	7	8	M2X0.4	1.5	1.3	0.7	5	3.5	15	3.5	2.2	1.1	M3X0.5
LRM7N	8	1.5	17	5	24.3	13.5	8	12	M2X0.4	2.3	1.7	0.7	7	4.7	15	4.2	2.4	2.4	M3X0.5
LRM7L	8	1.5	17	5	32.5	21.7	13	12	M2X0.4	2.3	1.7	0.7	7	4.7	15	4.2	2.4	2.4	M3X0.5
LRM9N	10	2	20	5.5	31	18.9	10	15	M3X0.5	2.8	2.2	1	9	5.6	20	6	3.5	3.4	M4X0.7
LRM9L	10	2	20	5.5	42.1	30	16	15	M3X0.5	2.8	2.2	1	9	5.6	20	6	3.5	3.4	M4X0.7
LRM12N	13	3	27	7.5	37.6	21.7	15	20	M3X0.5	4	3	1.5	12	7.5	25	6	3.5	4.4	M4X0.7
LRM12L	13	3	27	7.5	48.4	32.5	20	20	M3X0.5	4	3	1.5	12	7.5	25	6	3.5	4.4	M4X0.7
LRM15N	16	3.5	32	8.5	48	28	20	25	M3X0.5	4	3.7	M3	15	9.5	40	6	3.5	4.4	M4X0.7
LRM15L	16	3.5	32	8.5	65	45	25	25	M3X0.5	4	3.7	M3	15	9.5	40	6	3.5	4.4	M4X0.7

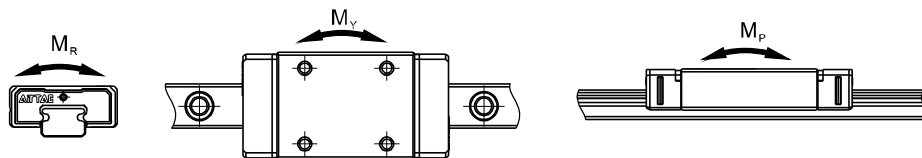

Model/Item	Mounting Screw	Dynamic Load Rating(kN)	Static Load Rating(kN)	Static Rated Moment (N.m)			Weight	
		C <sub>100B</sub>	C <sub>0</sub>	M <sub>R</sub>	M <sub>P</sub>	M <sub>V</sub>	Block(kg)	Rail(kg/m)
LRM5N	M2	0.33	0.55	1.68	0.99	0.99	0.0035	0.114
LRM5L	M2	0.48	0.9	2.4	2.08	2.08	0.004	0.114
LRM7N	M2	1.02	1.53	5.42	3.17	3.17	0.009	0.22
LRM7L	M2	1.43	2.45	9.27	7.96	7.96	0.014	0.22
LRM9N	M3	1.97	2.6	11.84	8.19	8.19	0.018	0.315
LRM9L	M3	2.61	4.11	19.73	18.94	18.94	0.027	0.315
LRM12N	M3	3.04	3.86	23.63	12.57	12.57	0.037	0.602
LRM12L	M3	3.96	5.9	40.96	32.57	32.57	0.053	0.602
LRM15N	M3	4.27	5.7	45.05	23.05	23.05	0.054	0.981
LRM15L	M3	6.53	9.53	70.08	63.69	63.69	0.088	0.981

### Accuracy

LRM miniature linear guide comes with 2 accuracy levels.

Accuracy Standards (mm)	Accuracy Standards (mm)	
	H: High	P: Precision
Tolerance of height H	±0.02	±0.01
Variation of height ΔH	0.015	0.007
Tolerance of width Y	±0.025	±0.015
Variation of width ΔY	0.02	0.01

Parallelism of motion relative to benchmark surface.

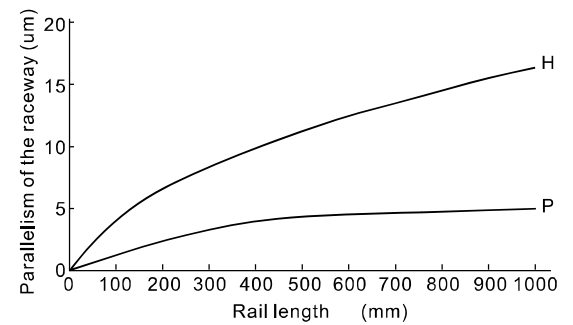

### Preload Level

LRM Miniature Linear Guide has three preload categories: A, B and C.

Choosing suitable preload level will enhance rigidity, precision and torsion resistant performance of the linear guide.

Preload Level	Code	Radial interference (μm)					Application
		5	7	9	12	15	
Standard clearance	A	-1~+2	-2~+2	-2~+2	-2~+3	-2~+3	Smooth operation
Light Preload	B	-3~-1	-4~-2	-5~-2	-6~-2	-7~-2	High Precision
Medium Preload	C	-6~-2	-7~-3	-8~-4	-9~-5	-10~-6	High rigidity

### Load Capacity and Rating Life

#### 1. Basic static load rating(C<sub>0</sub>)

It is defined as the static load when the total permanent deformation of the steel ball and the surface of the groove is exactly one ten-thousandth of the diameter of the steel ball under the state of the load direction and size unchanged.

#### 2. Static Permissible Moment(M<sub>0</sub>)

When the steel ball subjected to the maximum stress in the slider reaches a static rated load condition, this loading moment is called the "Static permissible moment". The definition comes in three directions.

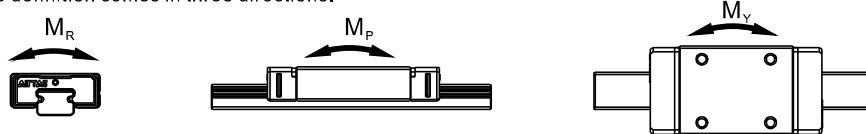

#### 3. Static Safety Factor(f<sub>s</sub>)

Impact, vibration and inertial loading during start and stop moment lead to unexpected load on the linear guide way. Therefore, when calculating the static load, safety factors must be considered.

Load Condition	f <sub>s</sub>
Normal Load	1.0~2.0
Load with Impacts or Vibrations	2.0~3.0

$$f_s = \frac{C_0}{P} = \frac{M_0}{M}$$

f<sub>s</sub> : Static safety factor  
 C<sub>0</sub> : Basic static load rating (N)  
 M<sub>0</sub> : Static permissible moment (N.m)  
 P : Calculated working load (N)  
 M : Calculated applying moment (N.m)

#### 4. Load Factor(f<sub>w</sub>)

The loads acting on a linear guide way include the weight of block, the inertia load at the times of start and stop, and the moment loads caused by overhanging. Therefore, the load on a linear guide way should be divided by the empirical factor.

Loading condition	Service speed	f <sub>w</sub>
No impacts & vibration	V ≤ 15m/min	1~1.2
Small impacts	15m/min < V ≤ 60m/min	1.2~1.5
Normal load	60m/min < V ≤ 120m/min	1.5~2.0
With impacts & vibration	V > 120m/min	2.0~3.5

#### 5. Dynamic Load Rating(C<sub>100B</sub>)

C<sub>100B</sub> : (According to ISO 14728-1) As the direction and magnitude remains the same, C<sub>100B</sub> is the maximum workload for the product to maintain its nominal life at 100km of operation.

## LRM Series

### 6. Calculation of Nominal Life(L)

Recognizing that nominal life of a linear guide is affected by the actual working loads, the general calculation of the nominal life excluding the environmental factors is carried out as follow :

$$L = \left( \frac{C_{100B}}{f_w \times P} \right)^3 \times 10^5$$

L = Nominal Life (m)

C<sub>100B</sub> = Dynamic Load Rating (N)

f<sub>w</sub> = Load Factor

P = Equivalent load (N)

Taking LRM9N for example, its C<sub>100B</sub> is 1.97kN. Therefore, when the product bears a 1.5kN equivalent load P, f<sub>w</sub>=1, its theoretical rated life can be calculated as follows:

$$L = \left( \frac{C_{100B}}{f_w \times P} \right)^3 \times 10^5 = \left( \frac{1.97}{1 \times 1.5} \right)^3 \times 10^5 = 226529 \text{ m} = 226.5 \text{ km}$$

## Installation Illustration

### 1. Height and Chamfer of Reference Edge

In order to ensure accurate installation of LRM Linear Guide, the contact space should not exceed the given figures in following table.

Unit : mm

Model	Q1	Q2	H1	R(Max)
LRM5	2	1.2	1.5	0.2
LRM7	3	1.2	1.5	0.2
LRM9	3	1.7	2	0.3
LRM12	4	2.7	3	0.4
LRM15	5	3.2	3.5	0.5

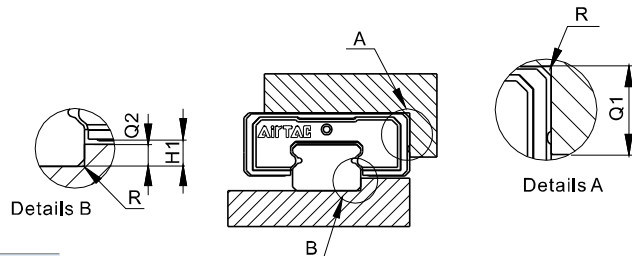

### 2. Screw Tighten Torque

Model	Screw size	Tighten Torque(N.cm)		
		Iron	Casting	Aluminum alloy
LRM5	M2	58.8	39.2	29.4
LRM7				
LRM9	M3	196	127	98
LRM12				
LRM15				

### 3. Datum plane

- Datum plane for installation must be ground or finely milled to ensure accuracy.
- Both sides of rail can be used as the datum plane.
- For multi-blocks on a rail, identification line on blocks should be put on the same side to ensure moving accuracy.

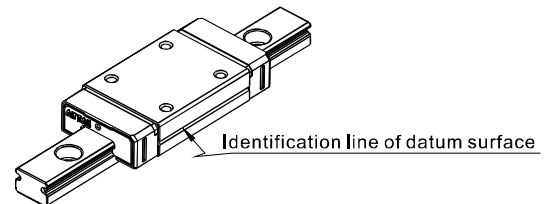

## Rail Butt-jointed

- When jointing rails, it must follow group marks on rail to ensure the accuracy of linear guide. These marks are located on the top surface at joint side. Please put the same group marks together.

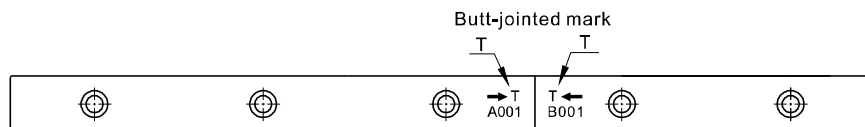

- Be aware serial number of group mark when assemble. A001 and B001 are in a group, so as to A002 and B002 and so on.
- Be aware the installation direction while assembly, the serial numbers are not upside down and arrows point to each other.

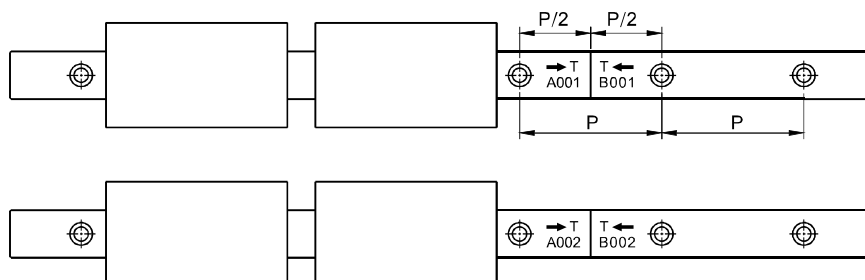

## LRM Series

### Lubrication Method

When a linear guide is well lubricated, it can reduce wear and increase lifespan significantly. Lubrication has the following benefits:

- Reduces friction of the rollers and rail to minimize wear.
- The grease film between contact surface can decrease the fatigue failure.
- Prevent rust.

#### 1. Lubrication method

LRM series linear guide is well lubricated with 'Synergy Grease PS NO.2' in factory.

Customers are recommended to use identical or the same grade of lubricant.

Please refer to the right table for the amount of oil:

In order to be well lubricated, the blocks need to be moved back and forth after lubricating.

Lubrication can be done either by manual or automatic device.

Model	Initial lubrication (cm <sup>3</sup> )	Replenishment amount (cm <sup>3</sup> )
LRM5N	0.02	0.01
LRM5L	0.03	0.015
LRM7N	0.1	0.05
LRM7L	0.13	0.07
LRM9N	0.2	0.1
LRM9L	0.28	0.14
LRM12N	0.34	0.17
LRM12L	0.45	0.23
LRM15N	0.72	0.36
LRM15L	1.0	0.50

#### 2. Lubrication frequency

Although the linear guides are well lubricated at the factory and retains grease well, frequent lubrication is still necessary to avoid undesirable wear.

Recommended lubrication period is every 100km of movement or every 3~6 months.

(Refer to table on the right for suggested amount).

### Precautions on use

#### 1. Block disassembly

LRM is equipped with ball retainers to prevent steel balls from falling out when block separates from rail. However, if obliquely insert rail into blocks or quickly assemble and disassemble, there is risk for steel balls of falling out. Please carefully assemble the linear guide or use plastic rails to assist.

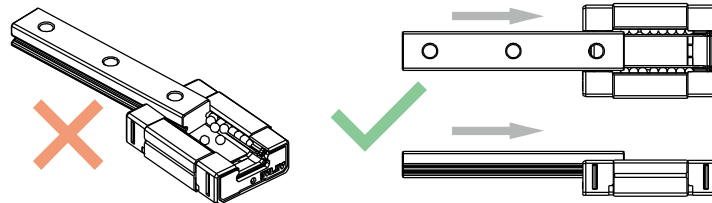

#### 2. Caution

- Parts may slide out if linear guide is put unevenly. Please be careful.
- Hitting or dropping a linear guide could have huge effects on accuracy and lifespan even though appearance may remain intact. Please be careful.
- Do not separate linear guide as external objects may enter blocks and cause accuracy problem.

#### 3. Lubrication

- Linear guide have been treated with anti-rust oil during production. Before use, wipe the rail and treat it with lubrication.
- Do not mix lubricating oil (grease) with different properties.
- While lubricating, the block needs to be moved back and forth. After lubrication, there should be a grease film on rail.

#### 4. Use

- The operating environment temperature should not exceed 80°C, and the maximum temperature should not exceed 100°C.
- Do not separate blocks from rail whenever it is not necessary. If you need to separate them, please use plastic rails to prevent steel balls from falling out.

#### 5. Storage

- When storing blocks, rails or set, please be sure that anti-rust oil is well applied and product is well sealed as well as placed horizontally. Avoid humidity and high temperatures environment.



# LGC Series Crossed Roller Way

## Product Introduction

Crossed Roller provides high rigidity and high accuracy linear movement with non-recirculating rollers design. By cross-arrangement of rollers, it will hugely reduce friction meanwhile provide high rigidity for rollers to bear heavy loads. Crossed roller is mainly used in high precision machine and measurement equipment such as circuit board printer, optical measurement instrument, X-ray equipment or base for multiple kinds of instruments.

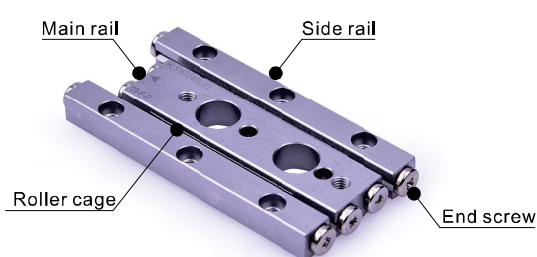

Three-Row Type Of Crossed Roller Way

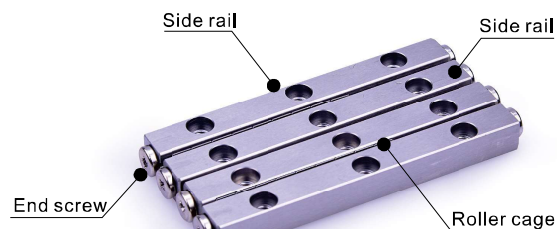

Four-Row Type Of Crossed Roller Way



Cylindrical roller with high precision roundness and wear resistance (JIS B 1506 G2) is manufactured in Japan

## Order Information

LGC 3 A 200 R25 -H

- ①
- ②
- ③
- ④
- ⑤
- ⑥



① Model Code	LGC : Crossed Roller Way			
② Roller Diameter	1 : $\Phi$ 1.5mm	2 : $\Phi$ 2.0mm	3 : $\Phi$ 3.0mm	4 : $\Phi$ 4.0mm 6 : $\Phi$ 6.0mm
③ Type [Note]	A: Three-row type [Note]		B: Four-row type	
④ Rail dimension	200: rail length 200X100: main rail length is 200mm/side rail length is 100mm [Reference to spec. table for detail]			
⑤ The number of rollers in each roller cage	R25: 25 rollers ..... [Reference to spec. table for detail]			
⑥ Accuracy	H : High		P : Precision	

[Note] LGC6: only for type B.



# Crossed Roller Way

## LGC Series

### Cross Reference Table for Maximun Stroke & Roller numbers

LGC1		Numbers of rollers in one roller cage								
Max. Stroke (mm)	R6	R7	R8	R9	R10	R11	R13	R16	R19	
Shortest length of rails (mm)	20	12	7	-	-	-	-	-	-	
	30	-	-	22	17	12	7	-	-	
	40	-	-	-	-	27	17	-	-	
	50	-	-	-	-	-	37	22	7	
	60	-	-	-	-	-	-	42	27	
	70	-	-	-	-	-	-	-	47	
	80	-	-	-	-	-	-	-	67	

The standard quantity of rollers

Alternative options of the quantity of rollers

LGC3		Numbers of rollers in one roller cage												
Max. Stroke (mm)	R7	R8	R9	R10	R11	R13	R16	R19	R22	R25	R28	R32	R36	R40
Shortest length of rails (mm)	50	34	24	14	-	-	-	-	-	-	-	-	-	-
	75	-	-	-	54	44	24	-	-	-	-	-	-	-
	100	-	-	-	-	74	44	-	-	-	-	-	-	-
	125	-	-	-	-	-	94	64	-	-	-	-	-	-
	150	-	-	-	-	-	-	114	84	54	-	-	-	-
	175	-	-	-	-	-	-	-	134	104	74	-	-	-
	200	-	-	-	-	-	-	-	-	154	124	84	-	-
	225	-	-	-	-	-	-	-	-	-	174	134	94	-
	250	-	-	-	-	-	-	-	-	-	-	184	144	104
	275	-	-	-	-	-	-	-	-	-	-	-	234	194
300	-	-	-	-	-	-	-	-	-	-	-	-	244	204

LGC2		Numbers of rollers in one roller cage													
Max. Stroke (mm)	R6	R7	R8	R9	R10	R11	R13	R16	R19	R22	R25	R28	R32	R36	
Shortest length of rails (mm)	30	16	8	-	-	-	-	-	-	-	-	-	-	-	
	45	-	-	30	22	14	-	-	-	-	-	-	-	-	
	60	-	-	-	-	-	36	20	-	-	-	-	-	-	
	75	-	-	-	-	-	-	50	26	-	-	-	-	-	
	90	-	-	-	-	-	-	-	56	32	-	-	-	-	
	105	-	-	-	-	-	-	-	-	62	38	-	-	-	
	120	-	-	-	-	-	-	-	-	-	68	44	-	-	
	135	-	-	-	-	-	-	-	-	-	98	74	50	-	
	150	-	-	-	-	-	-	-	-	-	-	104	80	48	
	165	-	-	-	-	-	-	-	-	-	-	-	110	78	45
180	-	-	-	-	-	-	-	-	-	-	-	-	140	108	76

LGC4		Numbers of rollers in one roller cage														
Max. Stroke (mm)	R8	R9	R10	R11	R13	R16	R19	R22	R25	R28	R32	R36	R40	R45		
Shortest length of rails (mm)	80	54	40	26	-	-	-	-	-	-	-	-	-	-		
	120	-	-	-	92	64	-	-	-	-	-	-	-	-		
	160	-	-	-	-	-	102	60	-	-	-	-	-	-		
	200	-	-	-	-	-	-	140	98	56	-	-	-	-		
	240	-	-	-	-	-	-	-	178	136	94	-	-	-		
	280	-	-	-	-	-	-	-	-	216	174	118	-	-		
	320	-	-	-	-	-	-	-	-	-	254	198	142	86		
	360	-	-	-	-	-	-	-	-	-	-	278	222	166	96	
	400	-	-	-	-	-	-	-	-	-	-	-	358	302	246	176
	440	-	-	-	-	-	-	-	-	-	-	-	-	382	326	256
480	-	-	-	-	-	-	-	-	-	-	-	-	-	406	336	

LGC6		Numbers of rollers in one roller cage												
Max. Stroke (mm)	R8	R9	R11	R13	R16	R19	R22	R25	R28	R32	R36	R40	R45	
Shortest length of rails (mm)	100	62	44	-	-	-	-	-	-	-	-	-	-	
	150	-	-	108	72	-	-	-	-	-	-	-	-	
	200	-	-	-	-	118	64	-	-	-	-	-	-	
	250	-	-	-	-	-	164	110	56	-	-	-	-	
	300	-	-	-	-	-	-	210	156	102	-	-	-	
	350	-	-	-	-	-	-	-	256	202	130	-	-	
	400	-	-	-	-	-	-	-	-	302	230	158	-	
	450	-	-	-	-	-	-	-	-	-	330	258	186	
	500	-	-	-	-	-	-	-	-	-	-	358	286	196
	550	-	-	-	-	-	-	-	-	-	-	-	458	386
600	-	-	-	-	-	-	-	-	-	-	-	-	486	396

### Accuracy

#### Accuracy

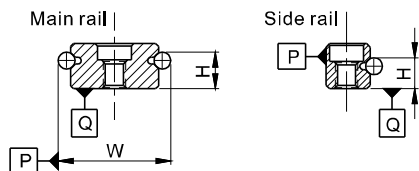

Unit : mm

Item	High(H)	Precision(P)
Tolerance of height H	±0.02	±0.01
Variation of height H	0.01	0.005
Tolerance of width W	±0.02	±0.01

#### Rail Length and Parallelism of The Raceway

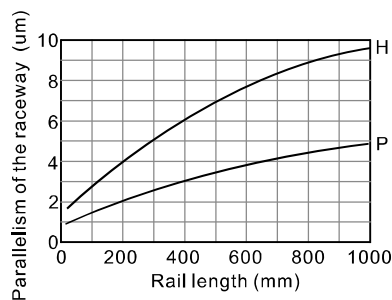

# Crossed Roller Way

## LGC Series

### Specification Table

#### Dimensions of Three-row Type

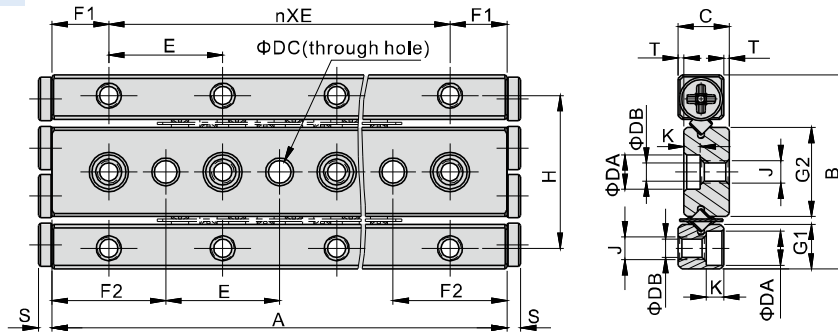

Model\Item	A	B	C	ΦDA	ΦDB	ΦDC	nXE	F1	F2	G1	G2	H	J	K	S	T
LGC1A20	20	17	4.5	3.0	1.55	2 <sup>+0.03</sup> / <sub>+0.005</sub>	1X10	5	10	3.9	7.8	13.4	M2X0.4	1.5	1.2	0.5
LGC1A30	30						2X10									
LGC1A40	40						3X10									
LGC1A50	50						4X10									
LGC1A60	60						5X10									
LGC1A70	70						6X10									
LGC1A80	80						7X10									
LGC2A30	30	24	6.5	4.4	2.5	3 <sup>+0.03</sup> / <sub>+0.005</sub>	1X15	7.5	15	5.5	11	19	M3X0.5	2.1	1.5	0.5
LGC2A45	45						2X15									
LGC2A60	60						3X15									
LGC2A75	75						4X15									
LGC2A90	90						5X15									
LGC2A105	105						6X15									
LGC2A120	120						7X15									
LGC2A135	135						8X15									
LGC2A150	150						9X15									
LGC2A165	165						10X15									
LGC2A180	180						11X15									
LGC3A50	50	36	8.5	6.0	3.4	4 <sup>+0.03</sup> / <sub>+0.005</sub>	1X25	12.5	25	8.3	16.6	29	M4X0.7	3.1	2	0.5
LGC3A75	75						2X25									
LGC3A100	100						3X25									
LGC3A125	125						4X25									
LGC3A150	150						5X25									
LGC3A175	175						6X25									
LGC3A200	200						7X25									
LGC3A225	225						8X25									
LGC3A250	250						9X25									
LGC3A275	275						10X25									
LGC3A300	300						11X25									
LGC4A80	80	44	11.5	7.5	4.3	5 <sup>+0.03</sup> / <sub>+0.005</sub>	1X40	20	40	10	20	35	M5X0.8	4.1	2	0.5
LGC4A120	120						2X40									
LGC4A160	160						3X40									
LGC4A200	200						4X40									
LGC4A240	240						5X40									
LGC4A280	280						6X40									
LGC4A320	320						7X40									
LGC4A360	360						8X40									
LGC4A400	400						9X40									
LGC4A440	440						10X40									
LGC4A480	480						11X40									

[Note] One set includes one main rail, two side rails, two roller cages, and the corresponding screws for mounting.

# Crossed Roller Way

## LGC Series

### Specification Table

#### Dimensions of Four-row Type

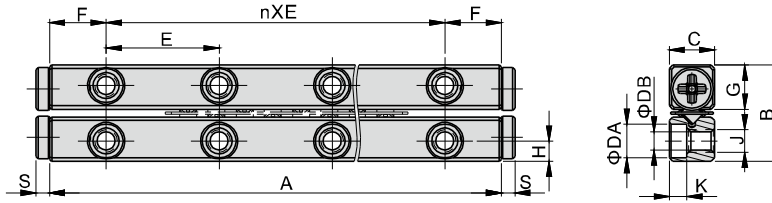

Model\Item	A	B	C	ΦDA	ΦDB	nXE	F	G	H	J	K	S
LGC1B20	20	8.5	4	3.0	1.55	1X10	5	3.9	1.8	M2X0.4	1.5	1.2
LGC1B30	30					2X10						
LGC1B40	40					3X10						
LGC1B50	50					4X10						
LGC1B60	60					5X10						
LGC1B70	70					6X10						
LGC1B80	80					7X10						
LGC2B30	30					12						
LGC2B45	45	2X15										
LGC2B60	60	3X15										
LGC2B75	75	4X15										
LGC2B90	90	5X15										
LGC2B105	105	6X15										
LGC2B120	120	7X15										
LGC2B135	135	8X15										
LGC2B150	150	9X15										
LGC2B165	165	10X15										
LGC2B180	180	11X15										
LGC3B50	50	18	8	6.0	3.4		1X25	12.5	8.3	3.5	M4X0.7	3.1
LGC3B75	75					2X25						
LGC3B100	100					3X25						
LGC3B125	125					4X25						
LGC3B150	150					5X25						
LGC3B175	175					6X25						
LGC3B200	200					7X25						
LGC3B225	225					8X25						
LGC3B250	250					9X25						
LGC3B275	275					10X25						
LGC3B300	300					11X25						
LGC4B80	80					22	11					
LGC4B120	120	2X40										
LGC4B160	160	3X40										
LGC4B200	200	4X40										
LGC4B240	240	5X40										
LGC4B280	280	6X40										
LGC4B320	320	7X40										
LGC4B360	360	8X40										
LGC4B400	400	9X40										
LGC4B440	440	10X40										
LGC4B480	480	11X40										
LGC6B100	100	31	15	9	5.3			1X50	25	14.7	6	M6X1.0
LGC6B150	150					2X50						
LGC6B200	200					3X50						
LGC6B250	250					4X50						
LGC6B300	300					5X50						
LGC6B350	350					6X50						
LGC6B400	400					7X50						
LGC6B450	450					8X50						
LGC6B500	500					9X50						
LGC6B550	550					10X50						
LGC6B600	600					11X50						

[Note] One set includes four side rails, two roller cages, and the corresponding screws for mounting.

### Roller Cage Order Information

LGC 3 R25

① ② ③



① Model Code	LGC : Crossed Roller Way
② Roller Diameter	1 : $\Phi$ 1.5mm 2 : $\Phi$ 2.0mm
③ The number of rollers	3 : $\Phi$ 3.0mm 4 : $\Phi$ 4.0mm 6 : $\Phi$ 6.0mm
	R25:25 rollers .... [Reference to spec. table for detail]

### Specification Table

#### Informations of Roller Cage

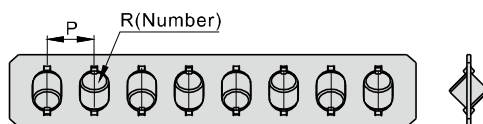

Model\Item	P	R	Basic Dynamic Load Rating (C <sub>d</sub> )	Basic Static Load Rating (C <sub>s</sub> )	Allowable Load (F <sub>o</sub> )	Model\Item	P	R	Basic Dynamic Load Rating (C <sub>d</sub> )	Basic Static Load Rating (C <sub>s</sub> )	Allowable Load (F <sub>o</sub> )
LGC1R6		6	125N per roller	120N per roller	39N per roller	LGC4R8		8	1230N per roller	1170N per roller	390N per roller
LGC1R7		7									
LGC1R8		8									
LGC1R9		9									
LGC1R10	2.5	10									
LGC1R11		11									
LGC1R13		13									
LGC1R16		16									
LGC1R19		19									
LGC2R6		6				292N per roller	290N per roller	97N per roller			
LGC2R7		7									
LGC2R8		8									
LGC2R9		9									
LGC2R10		10									
LGC2R11		11									
LGC2R13		13									
LGC2R16	4	16									
LGC2R19		19									
LGC2R22		22									
LGC2R25		25									
LGC2R28		28									
LGC2R32		32									
LGC2R36		36									
LGC3R7		7	640N per roller	610N per roller	203N per roller				LGC4R10		10
LGC3R8		8									
LGC3R9		9									
LGC3R10		10									
LGC3R11		11									
LGC3R13		13									
LGC3R16		16									
LGC3R19	5	19									
LGC3R22		22									
LGC3R25		25									
LGC3R28		28									
LGC3R32		32									
LGC3R36		36									
LGC3R40		40									
									LGC4R11		11
									LGC4R13		13
						LGC4R16		16			
						LGC4R19		19			
						LGC4R22	7	22			
						LGC4R25		25			
						LGC4R28		28			
						LGC4R32		32			
						LGC4R36		36			
						LGC4R40		40			
						LGC4R45		45			
						LGC6R8		8			
						LGC6R9		9			
						LGC6R11		11			
						LGC6R13		13			
						LGC6R16		16			
						LGC6R19		19			
						LGC6R22	9	22			
						LGC6R25		25			
						LGC6R28		28			
						LGC6R32		32			
						LGC6R36		36			
						LGC6R40		40			
						LGC6R45		45			

### Installation Illustration

#### Three-row type--Installation method 1

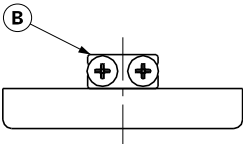
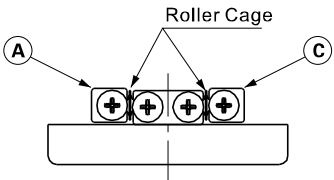
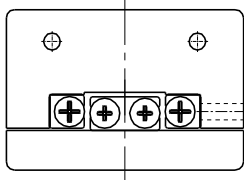
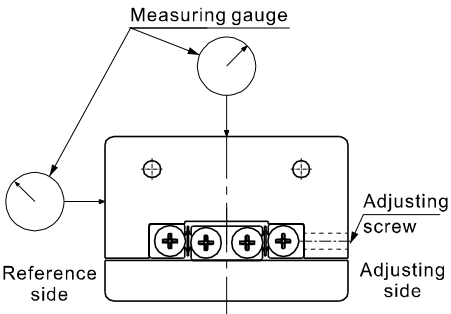
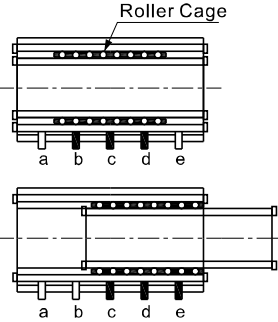
Step 1	Step 2	Step 3
<p>Lock the mounting screws on rail B with the recommended torque.</p> 	<p>Place the roller cage and rail A and C.</p> 	<p>Hold the rails to avoid moving, and temporarily fix the rail A and C after putting the slide table. Move the slide table back and forth to the end and adjust the roller cage to the center position of the rail.</p> 
<p>Fix the measuring gauges to the top surface center and side surface (reference side) of the slide table.</p> 	<p>Move the slide table and tighten the adjusting screws within the roller range. Repeat the movement until the value of the measuring gauge drops to the lowest and keeps no change, then tighten the adjusting screws a~e with correct torque.</p> 	<p>Tighten the rail A and C completely, then perform the same steps as tightening the adjusting screws, move the slide table and tighten the mounting screws within the roller range with recommended torque.</p>

#### Three-row type--Installation method 2

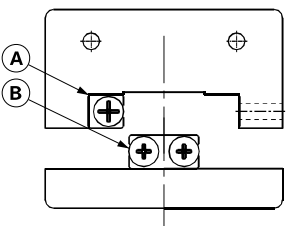
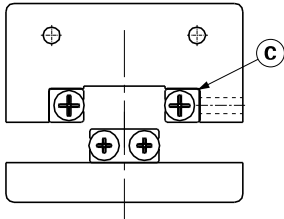
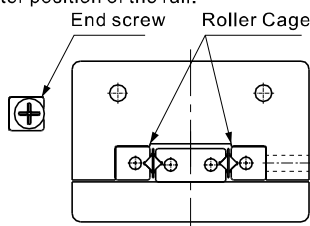
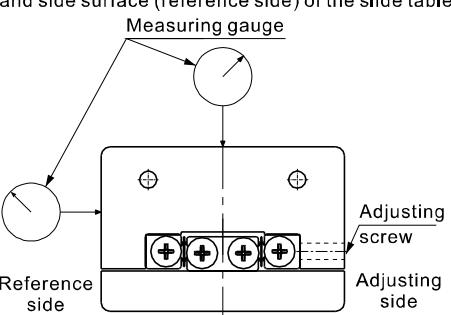
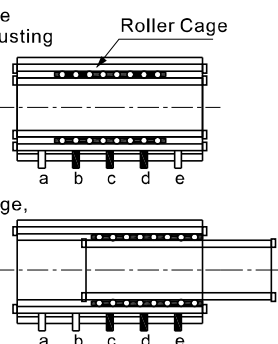
Step 1	Step 2	Step 3
<p>Lock the mounting screws on rail A and B with the recommended torque.</p> 	<p>Temporarily fix the rail C at the adjusting side.</p> 	<p>Removing the end screws on one side and insert the roller cage, then mount back the removed end screws and tighten. Move the slide table back and forth to the end and adjust the roller cage to the center position of the rail.</p> 
<p>Fix the measuring gauges to the top surface center and side surface (reference side) of the slide table.</p> 	<p>Move the slide table and tighten the adjusting screws within the roller range. Repeat the movement until the value of the measuring gauge drops to the lowest and keeps no change, then tighten the adjusting screws a~e with correct torque.</p> 	<p>Tighten the rail C completely, then perform the same steps as tightening the adjusting screws, move the slide table and tighten the mounting screws within the roller range with recommended torque.</p>

# Crossed Roller Way

## LGC Series

### Four-row type--Installation method 1

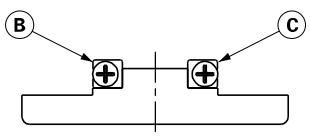
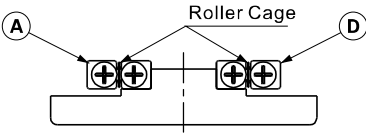
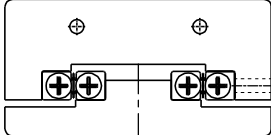
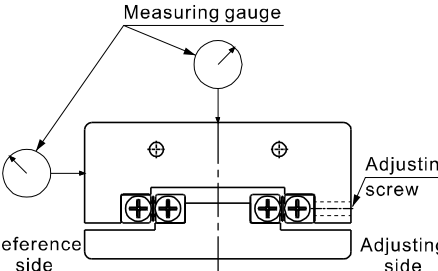
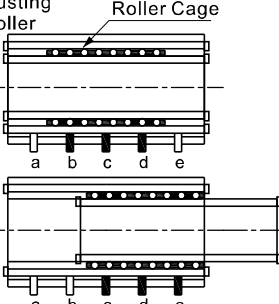
Step 1	Step 2	Step 3
<p>Lock the mounting screws on rail B and C with the recommended torque.</p> 	<p>Place the roller cage and rail A and D.</p> 	<p>Hold the rails to avoid moving, and temporarily fix the rail A and D after putting the slide table. Move the slide table back and forth to the end and adjust the roller cage to the center position of the rail.</p> 
Step 4	Step 5	Step 6
<p>Fix the measuring gauges to the top surface center and side surface (reference side) of the slide table.</p> 	<p>Move the slide table and tighten the adjusting screws within the roller range. Repeat the movement until the value of the measuring gauge drops to the lowest and keeps no change, then tighten the adjusting screws a~e with correct torque.</p> 	<p>Tighten the rail A and D completely, then perform the same steps as tightening the adjusting screws, move the slide table and tighten the mounting screws within the roller range with recommended torque.</p>

### Four-row type--Installation method 2

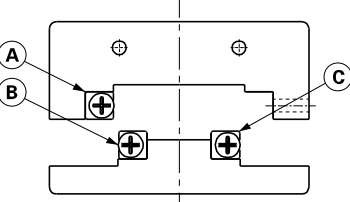
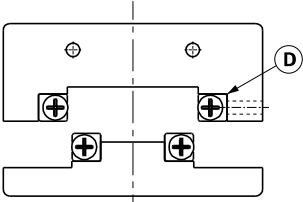
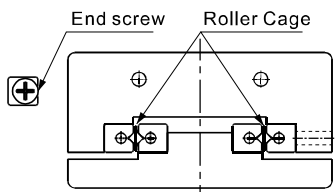
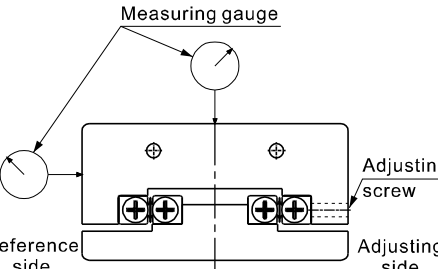
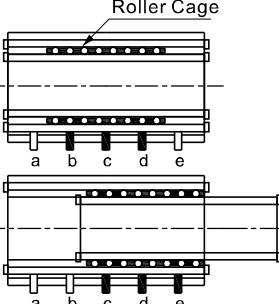
Step 1	Step 2	Step 3
<p>Lock the mounting screws on rail A, B and C with the recommended torque.</p> 	<p>Temporarily fix the rail D at the adjusting side.</p> 	<p>Removing the end screws on one side and insert the roller cage, then mount back the removed end screws and tighten. Move the slide table back and forth to the end and adjust the roller cage to the center position of the rail.</p> 
Step 4	Step 5	Step 6
<p>Fix the measuring gauges to the top surface center and side surface (reference side) of the slide table.</p> 	<p>Move the slide table and tighten the adjusting screws within the roller range. Repeat the movement until the value of the measuring gauge drops to the lowest and keeps no change, then tighten the adjusting screws a~e with correct torque.</p> 	<p>Tighten the rail D completely, then perform the same steps as tightening the adjusting screws, move the slide table and tighten the mounting screws within the roller range with recommended torque.</p>

### Clearance adjustment

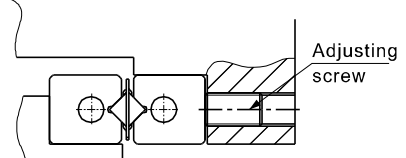
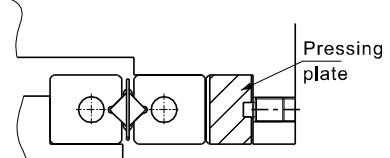
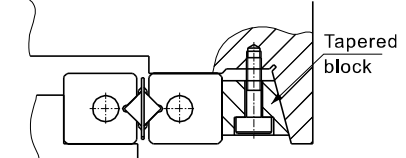
Application	Usually, the adjusting screw is used to push the rail on the adjusting side to adjust the clearance.	When rigidity and precision are required, pressing plate is recommended to adjust the clearance.	When high rigidity and high precision are particularly required, tapered block is recommended to adjust the clearance.
Diagram			

### User Manual

#### Load Rating

Load direction Type	Vertical load		Lateral load	
	Three-Row type	Four-Row type	Three-Row type	Four-Row type
Schematic				
Basic dynamic load rating - C <sub>a</sub> (N)	$C_a = \{2P \times (\frac{R}{2} - 1)\}^{\frac{1}{36}} \times (\frac{R}{2})^{\frac{3}{4}} \times C_1$ * Effective roller number R/2: round off to integer (EX : 5/2=2.5, take 2)		$C_a = \{2P \times (\frac{R}{2} - 1)\}^{\frac{1}{36}} \times (\frac{R}{2})^{\frac{3}{4}} \times 2^{\frac{7}{9}} \times C_1$ * Effective roller number R/2: round off to integer (EX : 5/2=2.5, take 2)	
Basic Static load rating - C <sub>a0</sub> (N)	C <sub>a0</sub> = R × C <sub>0</sub>		C <sub>a0</sub> = R × C <sub>0</sub>	
Allowable load - F <sub>a0</sub> (N)	F <sub>a0</sub> = R × F <sub>0</sub>		F <sub>a0</sub> = R × F <sub>0</sub>	

P: Pitch of roller cage (mm)  
 R: The number of cylindrical rollers incorporated in a roller cage  
 C<sub>1</sub>: Basic dynamic load rating per cylindrical roller (N)  
 C<sub>0</sub>: Basic static load rating per cylindrical roller (N)  
 F<sub>0</sub>: Allowable load per cylindrical roller (N)

Ex : Calculate LGC3A180R25 basic load rating  
 From specification table (Information of Roller Cage)  
 Pitch of roller cage : P=5mm  
 The number of cylindrical rollers incorporated in a roller cage : R = 25  
 Basic dynamic load rating per cylindrical roller : C<sub>1</sub> = 640 N  
 Basic static load rating per cylindrical roller : C<sub>0</sub> = 610 N  
 Allowable load per cylindrical roller : F<sub>0</sub> = 203 N  
 Effective roller number R/2 = 12.5, take 12  
 Take these parameters into calculation, we can get  
 For vertical load : Basic dynamic load rating C<sub>a</sub> = 4,701.88 N ;  
 Basic Static load rating C<sub>a0</sub> = 15,250 N ;  
 Allowable load F<sub>a0</sub> = 5,075 N ;  
 For Lateral load : Basic dynamic load rating C<sub>a</sub> = 8,061.31 N ;  
 Basic Static load rating C<sub>a0</sub> = 15,250 N ;  
 Allowable load F<sub>a0</sub> = 5,075 N .

#### Static Safety Factor (f<sub>s</sub>)

Inertia force caused by impact, sudden start or stop will exert unexpected force on crossed roller guide. Therefore, safety factor based on working condition needs to be put into consideration, see as follows:

Load Condition	f <sub>s</sub>
Normal Load	1.0~1.3
Load with Impacts or Vibrations	2.0~3.0

$$f_s = \frac{C_{a0}}{F}$$

f<sub>s</sub>: Static safety factor  
 C<sub>a0</sub>: Basic static load rating (N)  
 F: Calculated working load (N)

#### Nominal Life (L)

Nominal life is calculated as follow:

$$L = \left(\frac{f_t}{f_w} \cdot \frac{C_a}{F}\right)^{\frac{10}{3}} \times 100$$

L: Nominal life (km)  
 C<sub>a</sub>: Basic dynamic load rating (N)  
 F: Calculated working load (N)  
 f<sub>t</sub>: Temperature factor (Reference to Temperature Factor Chart)  
 f<sub>w</sub>: Load factor (Reference to Load Factor Table)

#### Calculating the Service Life Time (L<sub>n</sub>)

Based on the calculated nominal life, the Service Life Time is obtained through the following equation as if the stroke length and the value of reciprocations per minutes remain constant.

$$L_n = \frac{L \times 10^3}{2 \times l_s \times m \times 60}$$

L<sub>n</sub>: Service life time (h)  
 l<sub>s</sub>: Stroke length (mm)  
 m: Rounds per minute (min<sup>-1</sup>)

#### Temperature Factor (f<sub>t</sub>)

If the environmental temperature exceeds 100°C, take the adverse effect of the high temperature into account by multiplying the basic load ratings by the temperature factor.

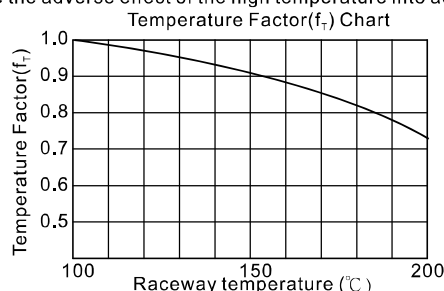

## LGC Series

### Load Factor( $f_w$ )

In general, reciprocating machines tend to involve vibrations or impact during operation. It is extremely difficult to accurately determine the impact caused by high-speed motion or frequent start and stop motion. However, the calibrated load can be expected by experience. The basic load rating ( $C_a$  or  $C_{a0}$ ) divide by load factor ( $f_w$ ) in the following table to calibrate from speed effect and vibrations.

Load Factor Table		
Vibrations/Impact	Speed(V)	$f_w$
Faint	$V \leq 0.25\text{m/s}$	1~1.2
Weak	$0.25 < V \leq 1\text{m/s}$	1.2~1.5

### Stroke

When moving, roller cage will move along with rail about half of its moving distance. Therefore, distance between center of loads and roller cage will vary with motion. In order to maintain accuracy, please conform to 'Cross Reference Table for Max. Stroke & Roller Numbers' table when deciding specs.

EX: Choose spec for a roller diameter 6 mm, high accuracy type and desiring length of rails are 300 and 200 mm, desiring moving distance is 50 mm. Refer to 'Cross Reference Table for Max. Stroke & Roller Numbers': roller diameter 6 mm with 200 mm as shortest rail, its roller numbers can be R16 or R19, and admissible moving distance is 118 and 64 mm respectively.

Both roller numbers can meet the required working distance 50mm.

### Mounting Screw

Tightening torque for fixing screw

Spec	Screw size	Tightening torque(N.m)
LGC1	M1.4X0.3PX6L	0.14
LGC2	M2.0X0.4PX8L	0.40
LGC3	M3.0X0.5PX9.5L	1.40
LGC4	M4.0X0.7PX16L	3.20
LGC6	M5.0X0.8PX20L	6.60

### Adjusting Screw

Tightening torque for fixing screw

Spec	Screw size	Tightening torque(N.m)
LGC1	M2	0.008
LGC2	M3	0.012
LGC3	M4	0.05
LGC4	M4	0.08
LGC6	M5	0.2

### Gap between adjusting screws

It must have more than 2 of adjusting screws even the rails are short. When the rails are long, the gap between adjusting screws are recommended in the table below:

Spec	Gap between adjusting screws(mm)
LGC1	10
LGC2	15
LGC3	25
LGC4	40

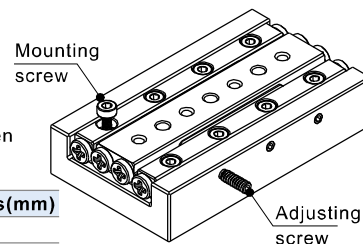

※High strength screw is preferred.

### Allowable preload

Excessive preload will cause dents or shorten the lifetime, refer to the table below for allowable preload clearance. And check the amount of displacement of roller contact part while tightening the adjustment screw.

Spec	LGC1	LGC2	LGC3	LGC4
Allowable preload (um)	-2	-3	-4	-5

### Precautions on dispensing

To avoid the screws from falling off by vibration, the screws thread can be dispensed before tightening. However, glue should not spill onto the roller and its contact surface to avoid affecting the walking accuracy.

### Precautions on lubrication

- Linear guides have been treated with anti-rust oil in the factory. Before use, wipe the rail and treat with lubrication.
- When adding grease, in order to avoid the sliding resistance caused by uneven oil film, run back and forth several times before operation.
- Do not mix lubricating oil (grease) with different properties. Even if the thickeners of different grease are the same, they may affect each other due to different additives.
- In special environments such as places with frequent vibration, clean rooms, vacuum, low temperature or high temperature, use grease that meets the specifications and environment.
- Pay attention to that the consistency of the grease changes depending on the temperature, so the sliding resistance also changes.
- After adding grease, excess grease may splash around during operation, so wipe excess grease before using it when necessary.
- In order to avoid insufficient lubrication caused by grease loss, grease inspection and replenishment are required according to the frequency of use. The lubrication frequency varies depending on the use conditions and the environment, hence the lubrication frequency and replenishment should be set according to the actual operation.

### Precautions on safety

- In high-speed use or bearing bias load, vibration, etc., roller cage offset may occur (Note 1), to avoid excessive extrusion, the stroke must be reserved when using, it is recommended that the operating stroke is slightly less than the maximum stroke to avoid cage extrusion damage.
- In order to obtain a high walking accuracy, it is recommended that the rail mounting surface should be ground to reach the same level or higher level to the parallelism and flatness of the rail, and the rails should be installed correctly close to the mounting surface.
- Be sure to remove the burrs, dents, dust, foreign objects, etc. of the rail mounting surface on the slide table and base, and pay attention to protection during assembly. When adjusting the preload, it is generally recommended to apply no or very small preload. Excessive preload can cause indentation damages and shorten the service life.

### Precautions on use

#### 1. Caution in handling

Dropping crossed roller way may cause damage on surface and further affect its accuracy, and even jerks during movement.

#### 2. Adjustment

Fail to adjust the preload or mounting surfaces correctly will affect the product lifetime and accuracy. Make sure to assemble, install, and adjust the product with care. Appropriate preload will help with rigidity and accuracy; yet overloading the crossed roller way will result in damages and deformation. On installation, please follow the installation procedure and recommended torque.

#### 3. Use as a Set

The accuracy of crossed roller guide is controlled as a set. Accuracy is not guaranteed when mixing parts from different sets.

#### 4. Allowable Load

Definition of allowable load is the maximum loads applied on crossed roller to cause acceptable elastic deformation while maintain a smooth movement. When working condition requires high accuracy and smooth movement, be sure load applied on product is under allowable load.

#### 5. Cage Slippage

The roller cage could slip under high speed motion, vertical use application, unbalanced load, and vibration conditions. Avoiding excessive loads is recommended. Meanwhile, using crossed roller within range of allowable stroke while applying safety factors will help avoid compression and damage.

#### 6. Possible causes of cage offset

- A. Vertical installation B. High speed or high acceleration application. C. Thermal deformation.  
D. Structure rigidity or accuracy of the base or slide table are insufficient. E. Incorrect installation (the rails are not correctly aligned or have uneven preload)

#### 7. Method of avoiding cage offset

During use, perform full-stroke movement multiple times to move the cage to the center position. In vertical installation, the cage is affected by gravity and offset probability increases, hence the stroke must be reserved, if the situation is not improved, LRM/LSH series are recommended to use, in this case cage offset will not happen.