



7V Series Solenoid valve(5/2 way,5/3 way)

Compendium of 7V Series

Inner exhaust structure

Special structure in the valve body, which can collect pilot airflow, and then exhaust intensively from R, S port.

Terminal

Special design for terminal, horizontal and vertical insertion can freely switch.

Multi-port types are optional

Threaded type and quick connector type are optional, and can integrate manifold to form valve group to save space.



Multi-series and type

7V0500, 7V100, 7V200, 7V300 series are optional.

Die-cast molding with aluminum alloy for body

The shape of cavity is reasonable, which can increase flowing area and valve's flow.

Installation and Application

1. Don't throw or drop the solenoid valve when take it, to avoid breaking valve;
2. Because solenoid pilot valve is sophisticated component, can't crash pilot valve by outside force, otherwise solenoid valve break possibly;
3. Don't dismantle solenoid valve freely, if the screw(M1.6X14) becomes loose, please tighten it by torque 0.1~0.12N.m;
4. About manual operation:
 - 4.1. Ensure no danger, prior to activating manual override;
 - 4.2. For push button option:

Activate by push the button in the direction shown
 - 4.3. For slotted option:

Activate by push the button in the direction shown.
With correct size screw driver: please turn to lock gently(Torque: 0.1N.m).

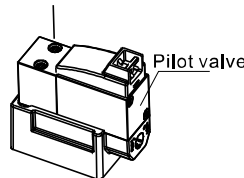

Attention



Normal position



Lucked position

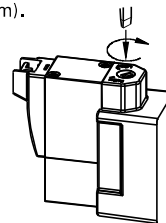

- 4.4. Wiring instruction: Vertical plug type and parallel plug type are the same as plug, please insert wire line as up drawing by practicality.



Vertical plug wire



Parallel plug wire



Solenoid valve(5/2 way,5/3 way)

7V Series



Specification

Model	7V0510	7V0520	7V0530	7V110	7V120	7V130
Port size [Note1]	Thread type			In=Out=Exhaust=M5		
	Tube type			In=Out=Exhaust=1/8"		
Orifice size (Cv) [Note4]	M5:3.4mm ² (0.2)		7V0530CM5: 2.2mm ² (0.13)	06:8.0mm ² (0.47)		7V130C06: 7.0mm ² (0.41)
	Weight		30g	45g	50g	80g
Port size [Note1]	Thread type			In=Out=Exhaust=1/8"		
	Tube type			In=Out=3/8" Exhaust=1/4"		
Orifice size (Cv) [Note4]	08:14.7mm ² (0.87)		7V230C08: 10.8mm ² (0.64)	10:38.4mm ² (2.26)		7V330C10: 30.5mm ² (1.8)
	Weight		120g	135g	145g	230g
Fluid	Air(to be filtered by 40µm filter element)					
Acting	Pilot					
Operating pressure	7V0530/7V130		0.2~0.8MPa(29~114psi)			
	7V230/7V330		0.15~0.8MPa(21~114psi)			
Others		0.15~0.8MPa(21~114psi)				
Proof pressure	1.2MPa(175psi)					
Temperature	-10~50°C					
Material of body	Aluminum alloy					
Lubrication [Note2]	Not required					
Exhaust type of pilot valve	Main valve and pilot valve is centralized exhaust					
Max. frequency[Note3]	5 cycle/sec	3 cycle/sec	5 cycle/sec	3 cycle/sec	3 cycle/sec	3 cycle/sec

- [Note1] G thread is available.
 [Note2] Once lubricated air is used, continue with same medium to optimize valve life span. Lubricants like ISO VG32 or equivalent are recommended.
 [Note3] The maximum actuation frequency is in the no-load state.
 [Note4] Equivalent orifice S and Cv are all calculated from the flow rate data.

Symbol

7V0500/100/200



7V300



Product feature

1. Electrical entry is terminal, horizontal and vertical insertion can freely switch.
2. Inner exhaust structure, which can collect pilot airflow, and then exhaust intensively from R, S port.
3. Die-cast molding with aluminum alloy for body. The shape of cavity is reasonable, which can increase valve's flow.
4. Threaded type and quick connector type are optional, and can integrate manifold to form valve group to save space.

Coil specification

Item	Specification			
Standard voltage	AC220V	AC110V	DC24V	DC12V
Scrop of voltage	AC: +15% ~-10%		DC: ±10%	
Power of consumption	1.1VA		0.7W	
Protection	Dustproof			
Temperature classification	F Class			
Electrical entry	Terminal			
Activating time	0.05 sec and below			

Ordering code

7V 2 10 J 08 B 050 G



① Model	7V: 5 port 2(3) position solenoid valve					
② Code	05: 0500 Series	1: 100 Series	2: 200 Series	3: 300 Series		
③ Valve type	10: Single solenoid(5/2 Way)		20: Double solenoid(5/2 Way)		30C: Double solenoid(5/3 way closed center)	
	30E: Double solenoid(5/3 way Exhaust center)		30P: Double solenoid(5/3 way pressure center)			
④ Port type	Blank: Thread type		J: Tube type			
⑤ Port size	Thread type		M5: M5	06: 1/8"	08: 1/4"	10: 3/8"
	Tube type		04: Φ4mm	04: Φ4mm/06: Φ6mm/08: Φ8mm	08: Φ8mm/10: Φ10mm	-
⑥ Voltage	A: AC220V		B: DC24V	C: AC110V	F: DC12V	
⑦ Wire length	050: 0.5m		200: 2.0m			
⑧ Thread type	No this code		G: G Thread			

[Note 1]: The bottom ports of solenoid valve with tube type are oval, without thread type options and can only install with a manifold.

Solenoid valve(5/2 way,5/3 way)

7V Series

Flow chart

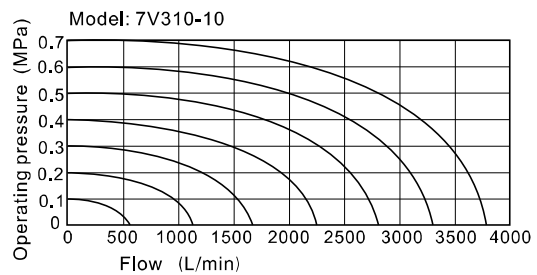
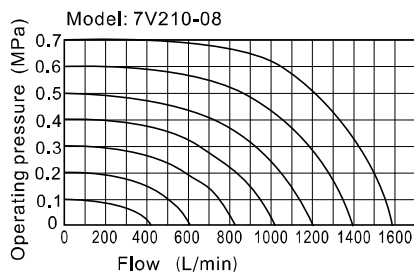
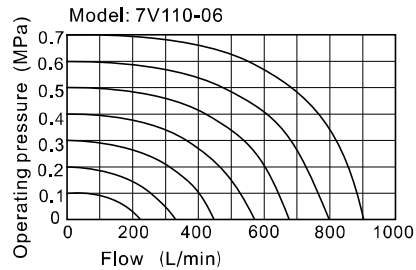
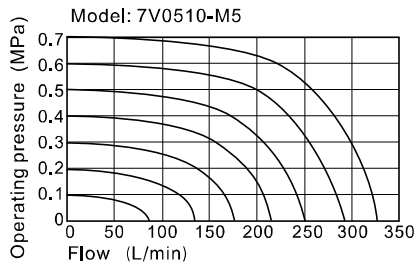

The data in flow rate chart are obtained from AirTAC lab.

Inner structure

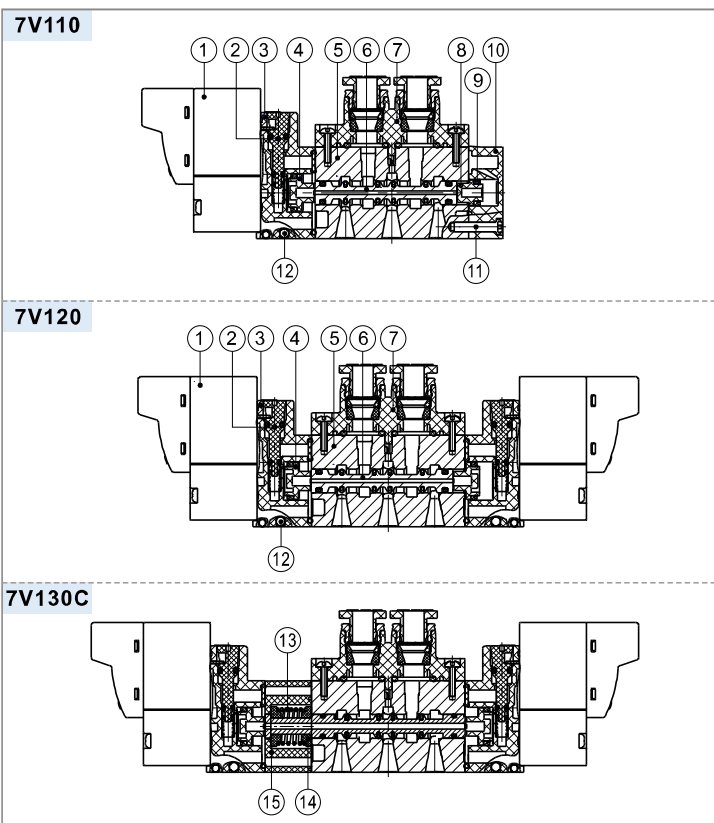

No.	Item	No.	Item	No.	Item
1	Pilot valve	6	Spool	11	Bolt
2	Manual override	7	Connecting block	12	Steel ball
3	Pilot kit	8	Little piston	13	Spring
4	Big piston	9	Gasket	14	Return holder
5	Body	10	Bottom cover	15	Side cover

Solenoid valve(5/2 way,5/3 way)

7V Series

Dimensions

7V0510
7V110
7V210
7V310

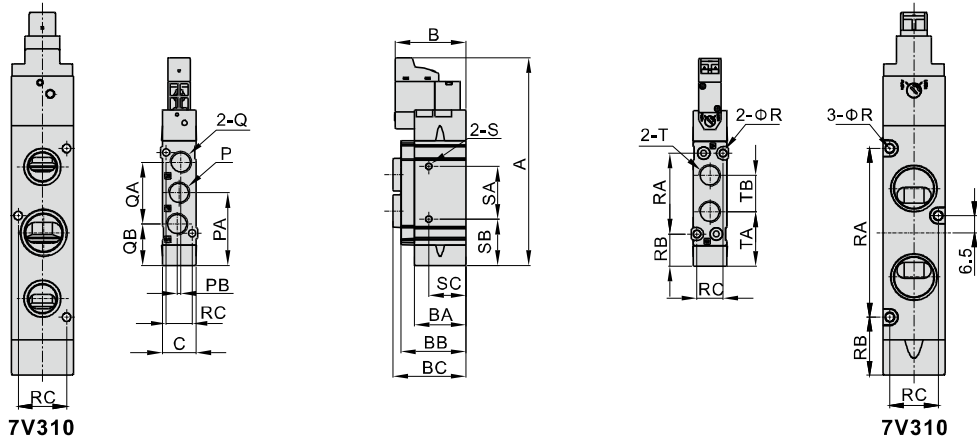

Model\Item	A	B	BA	BB	BC	C	P	PA	PB	Q	QA	QB	T	TA	TB	R	RA	RB	RC	S	SA	SB	SC	
7V0510M5	73	30.5	18.5	23	23.5	10	M5X0.8	22.5	1	M5X0.8	19	13	M5X0.8	17.5	10.5	2.1	21.4	12	8.6	M3X0.5dp3	9.5	17.8	4	
7V0510J04					32.5		Oval			Φ4(tube)			-							-				-
7V11006	92.5	32	23	29	32.5	15	1/8"	32.5	1.6	1/8"	27.2	18.5	1/8"	24	16.2	3.2	36	14.5	11.6	M3X0.5dp3	23.5	20.5	16.5	
7V110J04					38.2		Oval			Φ4(tube)			-							-				-
7V110J06					40					Φ6(tube)			-							-				-
7V110J08					41.5					Φ8(tube)			-							-				-
7V21008	106	33.5	28	34	40.5	18	1/4"	39	3	1/8"	36	21	1/4"	29	20	4.3	42	18	13.6	M4X0.7dp5	20	29	7	
7V210J08					46.5		Oval			Φ8(tube)			-							-				-
7V210J10					49					Φ10(tube)			-							-				-
7V31010					23.5					3/8"			3/8"							37				33.5

[Note]: The bottom ports of solenoid valve with tube type are oval and can only install with manifold (no side installation hole "S").

7V0520
7V120
7V220
7V320

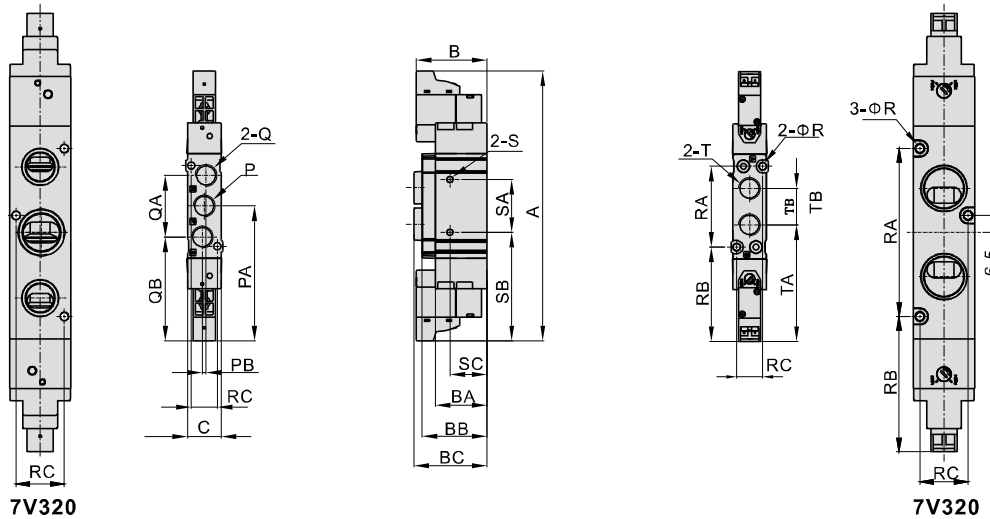

Model\Item	A	B	BA	BB	BC	C	P	PA	PB	Q	QA	QB	T	TA	TB	R	RA	RB	RC	S	SA	SB	SC	
7V0520M5	101.5	30.5	18.5	23	23.5	10	M5X0.8	50.5	1	M5X0.8	19	41	M5X0.8	45.5	10.5	2.1	21.4	12	8.6	M3X0.5dp3	9.5	17.8	4	
7V0520J04					32.5		Oval			Φ4(tube)			-							-				-
7V12006	120.5	32	23	29	32.5	15	1/8"	60.5	1.6	1/8"	27.2	46.5	1/8"	52	16.2	3.2	36	14.5	11.6	M3X0.5dp3	23.5	48.5	16.5	
7V120J04					38.2		Oval			Φ4(tube)			-							-				-
7V120J06					40					Φ6(tube)			-							-				-
7V120J08					41.5					Φ8(tube)			-							-				-
7V22008	134	33.5	28	34	40.5	18	1/4"	67	3	1/8"	36	49	1/4"	57	20	4.3	42	18	13.6	M4X0.7dp5	20	57	7	
7V220J08					46.5		Oval			Φ8(tube)			-							-				-
7V22008J10					49					Φ10(tube)			-							-				-
7V32010					23.5					3/8"			3/8"							67				33.5

[Note]: The bottom ports of solenoid valve with tube type are oval and can only install with manifold (no side installation hole "S").

Solenoid valve(5/2 way,5/3 way)

7V Series

7V0530
7V130
7V230
7V330

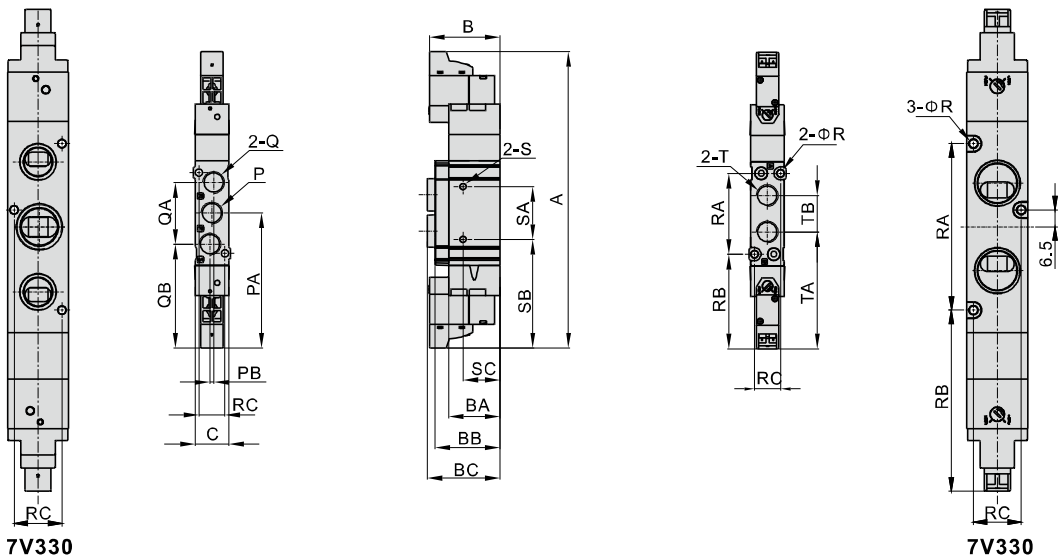

Model\Item	A	B	BA	BB	BC	C	P	PA	PB	Q	QA	QB	T	TA	TB	R	RA	RB	RC	S	SA	SB	SC
7V0530M5	110	30.5	18.5	23	23.5	10	M5X0.8	50.5	1	M5X0.8	19	41	M5X0.8	45.5	10.5	2.1	21.4	12	8.6	M3X0.5dp3	9.5	45.8	4
7V0530J04					32.5		Oval			Oval			Φ4(tube)							-	-	-	
7V130006	132	32	23	29	32.5	15	1/8"	60.5	1.6	1/8"	27.2	46.5	1/8"	52	16.2	3.2	36	14.5	11.6	M3X0.5dp3	23.5	48.5	16.5
7V130J04					38.2		Oval			Oval			Φ4(tube)							-	-	-	
7V130J06					40		Oval			Oval			Φ6(tube)							-	-	-	
7V130J08					41.5		Oval			Oval			Φ8(tube)							-	-	-	
7V230008	147	33.5	28	34	40.5	18	1/4"	67	3	1/8"	36	49	1/4"	57	20	4.3	42	18	13.6	M4X0.7dp5	20	57	7
7V230J08					46.5		Oval			Oval			Φ8(tube)							-	-	-	
7V230J10					49		Oval			Oval			Φ10(tube)							-	-	-	
7V33010					23.5		3/8"			1/4"			50							76.5	3/8"	85	33.5

[Note]: The bottom ports of solenoid valve with tube type are oval and can only install with manifold (no side installation hole "S").

Accessories—Mounting bracket

1. Ordering code

F-7V100 LB

① ② ③

① Accessories code	F: Mounting accessories
② Valve type	7V0500: 0500 Series 7V100: 100 Series 7V200: 200 Series
③ Accessories type	LB: LB Type(Side mounted) LBD: LB Type(Bottom mounted)

Note : 1. Each mounting bracket with 4pcs mounting screws.
2. Packed in PE bags with blank labels.

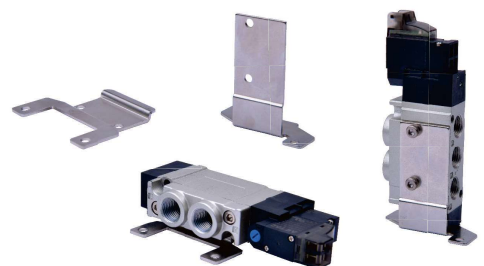

2. Dimensions

Side mounted

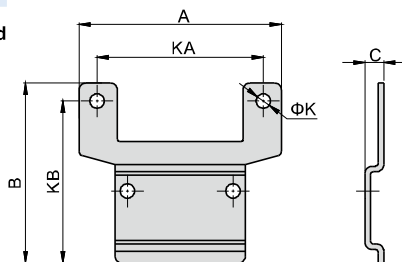

Model\Item	A	B	C	K	KA	KB
F-7V0500LB	35	35	4.2	3.2	27	31.5
F-7V100LB	45	40	4.2	3.2	37	36
F-7V200LB	66	49	4.2	4.2	52	42

Bottom mounted

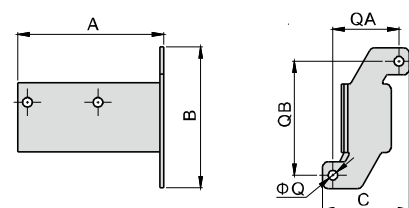

Model\Item	A	B	C	Q	QA	QB
F-7V0500LBD	32.5	38	24	3.2	17	31
F-7V100LBD	48.5	47	29	3.2	22	38
F-7V200LBD	57	57	38	4.2	28	46

7V Series manifold



Specification

Item\Manifold Model	7V0500M	7V100M	7V200M	7V300M
Fluid	Air(to be filtered by 40 μm filter element)			
Temperature	-20~70℃			
Adaptable valve's series	7V0500 Series	7V100 Series	7V200 Series	7V300 Series

Product feature

1. It is available to integrate the direction control valves of the same series to form valve group to save space and cost.
2. It is easy to examine when there are faults owing to the unified air intake and exhaust and unified wiring.
3. Flexible combination and strong expansion capability can make any combination or expansion of the numbers of direction control valves that are connected.

Ordering code

7V100M 5F G Ordering code for manifold



① Model	7V0500M: 7V0500 Series manifold	7V100M: 7V100 Series manifold	7V200M: 7V200 Series manifold	7V300M: 7V300 Series manifold
② Number of stations	1F: 1 Station 2F: 2 Station 3F: 3 Station 20F: 20 Station			
③ Thread type	G: G Thread			

P-7V100M-R2 Ordering code for blank plate



① Model	7V0500M: 7V0500 Series manifold	7V100M: 7V100 Series manifold	7V200M: 7V200 Series manifold	7V300M: 7V300 Series manifold
② Code	R2: Blank plate for manifold			

[Note] 1. Manifold kits contains manifold, seal and screw. 2. Blank plate kits contains blank plate and screw.

Dimensions

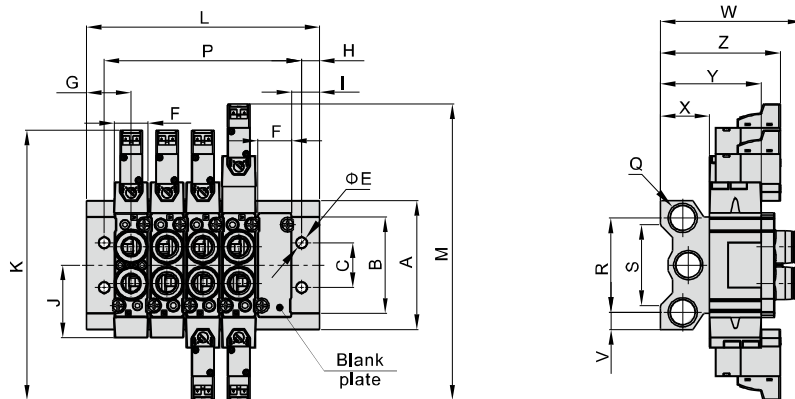

Model\Item	A	B	C	E	F	G	H	I	J	K	M	Q	R	S	V	W			X	Y	Z	
7V0500M	46	32	16	4.5	10	17.5	5	12.5	22.5	102	110	1/8"	32	26	7	41.5(M5)	50.5(J04)			17	35.5	47.5
7V100M	57.5	43	20	4.5	15	20	5	12.5	32	121	132	1/4"	40	36	9	55(06)	62.5(J04)/64(J06)	65.5(J08)	22	45	53.5	
7V200M	60	52	21	4.5	18	22	5	13	39	134	147	1/4"	42	38	9	65(08)	76.5(J08)	78.5(J10)	24	52	57	
7V300M	85	75	26	4.5	23.5	24	5	12	54	167	185	3/8"	57	58	14	-	-	-	27	74	-	

Model\Item	L																			
	1F	2F	3F	4F	5F	6F	7F	8F	9F	10F	11F	12F	13F	14F	15F	16F	17F	18F	19F	20F
7V0500M	30	40.5	51	61.5	72	82.5	93	103.5	114	124.5	135	145.5	156	166.5	177	187.5	198	208.5	219	229.5
7V100M	34	50	66	82	98	114	130	146	162	178	194	210	226	242	258	274	290	306	322	338
7V200M	37	56	75	94	113	132	151	170	189	208	227	246	265	284	303	322	341	360	379	398
7V300M	48	72	96	120	144	168	192	216	240	264	288	312	336	360	384	408	432	456	480	504

Model\Item	P																			
	1F	2F	3F	4F	5F	6F	7F	8F	9F	10F	11F	12F	13F	14F	15F	16F	17F	18F	19F	20F
7V0500M	20	30.5	41	51.5	62	72.5	83	93.5	104	114.5	125	135.5	146	156.5	167	177.5	188	198.5	209	219.5
7V100M	24	40	56	72	88	104	120	136	152	168	184	200	216	232	248	264	280	296	312	328
7V200M	27	46	65	84	103	122	141	160	179	198	217	236	255	274	293	312	331	350	369	388
7V300M	38	62	86	110	134	158	182	206	230	254	278	302	326	350	374	398	422	446	470	494