

Air valve(5/2 way, 5/3 way)

4A100 Series



Specification

Model	4A110-M5 4A120-M5	4A130C-M5 4A130E-M5 4A130P-M5	4A110-06 4A120-06	4A130C-06 4A130E-06 4A130P-06
Fluid	Air (to be filtered by 40 μm filter element)			
Acting	Exterior control			
Port size [Note1]	In=Out=M5		In=Out=1/8"	
Orifice size (Cv) [Note4]	4A110-06, 4A120-06: 10.2mm ² (Cv=0.6) 4A130C-06: 8.6mm ² (Cv=0.51)			
Valve type	5 port 2 position	5 port 3 position	5 port 2 position	5 port 3 position
Operating pressure	0.15~0.8MPa (21~114psi)			
Proof pressure	1.2MPa (175psi)			
Temperature	-20~70°C			
Material of body	Aluminum alloy			
Lubrication [Note2]	Not required			
Max. frequency [Note3]	5 cycle/sec	3 cycle/sec	5 cycle/sec	3 cycle/sec
Weight (g)	4A110-M5: 85 4A120-M5: 140	165	4A110-06: 85 4A120-06: 140	165

Symbol

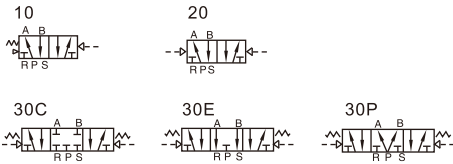

[Note1] G thread is available.

[Note2] Once lubricated air is used, continue with same medium to optimise valve life span. Lubricants like ISO VG32 or equivalent are recommended.

[Note3] The maximum actuation frequency of no-load state.

[Note4] Equivalent orifice S and Cv are all calculated from the flow rate data.

Product feature

1. Structure in sliding column mode: good tightness and sensitive reaction.
2. Three position air valves have three kinds of central function for your choice.
3. Double air control valves have memory function.
4. Internal hole adopts special processing technology which has little attrition friction, low start pressure and long service life.
5. No need to add oil for lubrication.
6. Integrate with the manifold to save installation space.

Ordering code

4A 1 10 06 G



① Model	② Code	③ Valve type	④ Port size	⑤ Thread type
4A: Air Valve(5/2, 5/3 way)	1: 100 Series	10: Single air control 5/2 way 20: Double air control 5/2 way 30C: Double air control 5/3 way closed center 30E: Double air control 5/3 way exhaust center 30P: Double air control 5/3 way pressure center	M5: M5 06: 1/8"	No this code G: G Thread

Please refer to P125 for manifold specification and the order way.

Flow chart

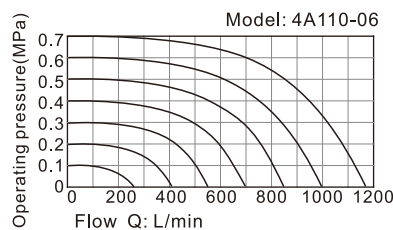

The data in flow rate chart are obtained from AirTAC lab.

Air valve(5/2 way, 5/3 way)

4A100 Series

Inner structure

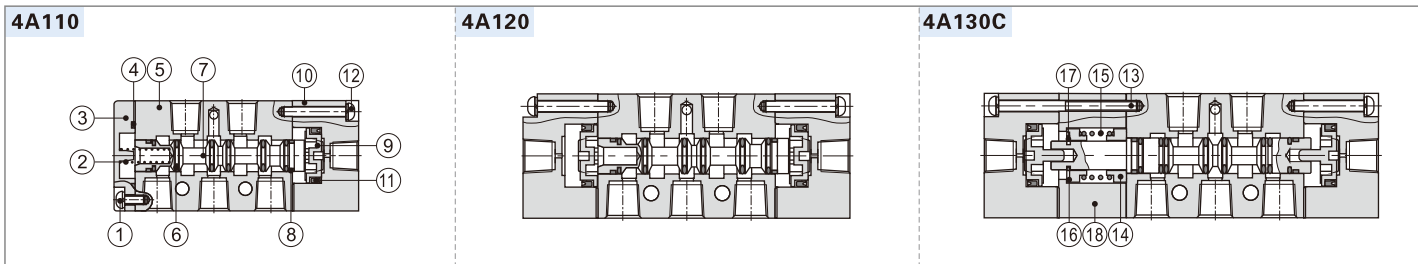

No.	Item	No.	Item	No.	Item	No.	Item	No.	Item	No.	Item	No.	Item	No.	Item	No.	Item
1	Screw	3	Bottom cover	5	Body	7	Spool	9	Piston	11	O-ring	13	Screw	15	Return Spring	17	E Clip
2	Spring	4	Bottom cover gasket	6	O-ring	8	Wear ring	10	Pilot body	12	Screw	14	Spring holder	16	Spring holder	18	Side cover

Dimension

4A110

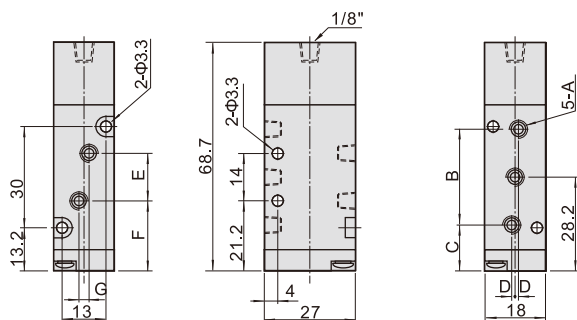

Model\Item	A	B	C	D	E	F	G
4A110-M5	M5x0.8	27	14.7	0	14	21.2	0
4A110-06	1/8"	28	14.2	1	16	20.2	3

4A120

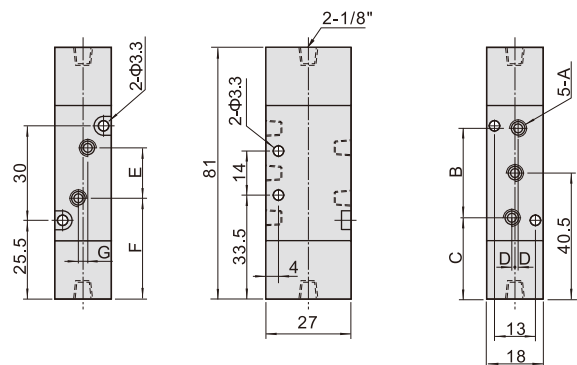

Model\Item	A	B	C	D	E	F	G
4A120-M5	M5x0.8	27	27	0	14	33.5	0
4A120-06	1/8"	28	26.5	1	16	32.5	3

4A130

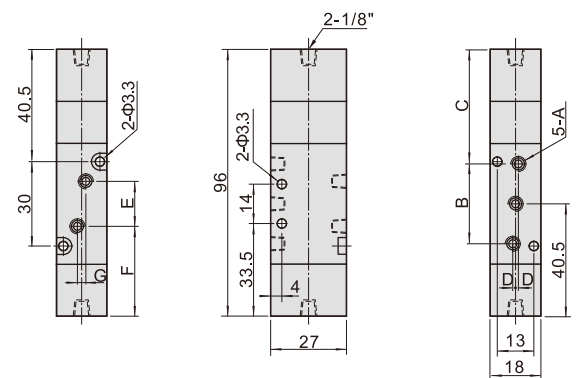

Model\Item	A	B	C	D	E	F	G
4A130-M5	M5x0.8	27	42	0	14	33.5	0
4A130-06	1/8"	28	41.5	1	16	32.5	3